



US 20110317009A1

(19) **United States**

(12) **Patent Application Publication**  
**Kumaraswamy et al.**

(10) **Pub. No.: US 2011/0317009 A1**

(43) **Pub. Date: Dec. 29, 2011**

(54) **CAPTURING EVENTS OF INTEREST BY SPATIO-TEMPORAL VIDEO ANALYSIS**

**Publication Classification**

(75) Inventors: **Suresh Kirthi Kumaraswamy**, Bangalore (IN); **Puneeth Bilagunda Chandrashekar**, Bangalore (IN); **Hemanth Kumar Sangappa**, Bangalore (IN); **Venu Belagur Krishnamurthy**, Chikmagalur District (IN)

(51) **Int. Cl.**  
*H04N 7/18* (2006.01)  
*G06K 9/34* (2006.01)  
(52) **U.S. Cl.** ..... **348/143; 382/173; 348/E07.085**

(73) Assignee: **MindTree Limited**

(57) **ABSTRACT**

(21) Appl. No.: **12/876,166**

A computer implemented method and system for capturing events of interest by performing a spatio-temporal analysis of a video are provided. A continuous video stream containing a series of image frames is acquired over time. Each of the image frames is represented by horizontal spatial coordinates and vertical spatial coordinates of a two dimensional plane. A temporal dimension is assigned across the image frames of the video stream. A spatio-temporal analysis image is constructed based on a user-defined line of analysis on each of one or more of the image frames. The spatio-temporal analysis image is constructed by concatenating a series of temporally-successive linear pixel arrays along the temporal dimension. Each of the linear pixel arrays comprises an array of pixels along the line of analysis defined on each of one or more of the image frames. The constructed spatio-temporal analysis image is segmented for capturing the events of interest.

(22) Filed: **Sep. 6, 2010**

(30) **Foreign Application Priority Data**

Jun. 23, 2010 (IN) ..... 1753/CHE/2010

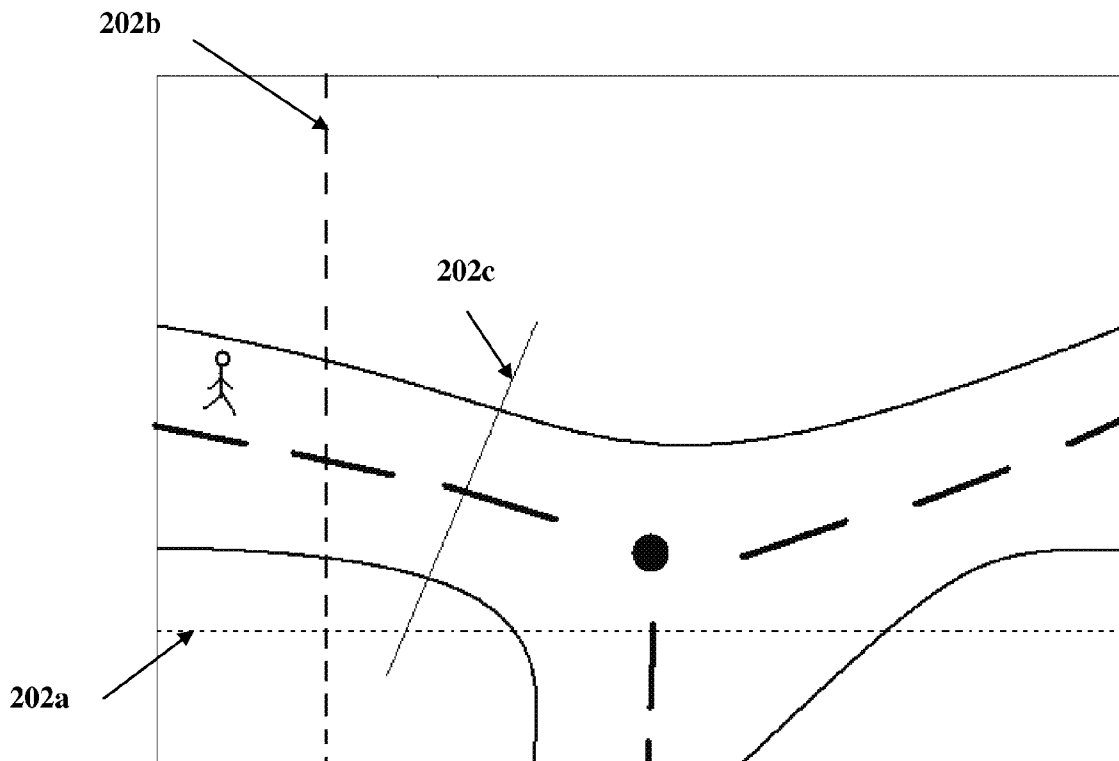

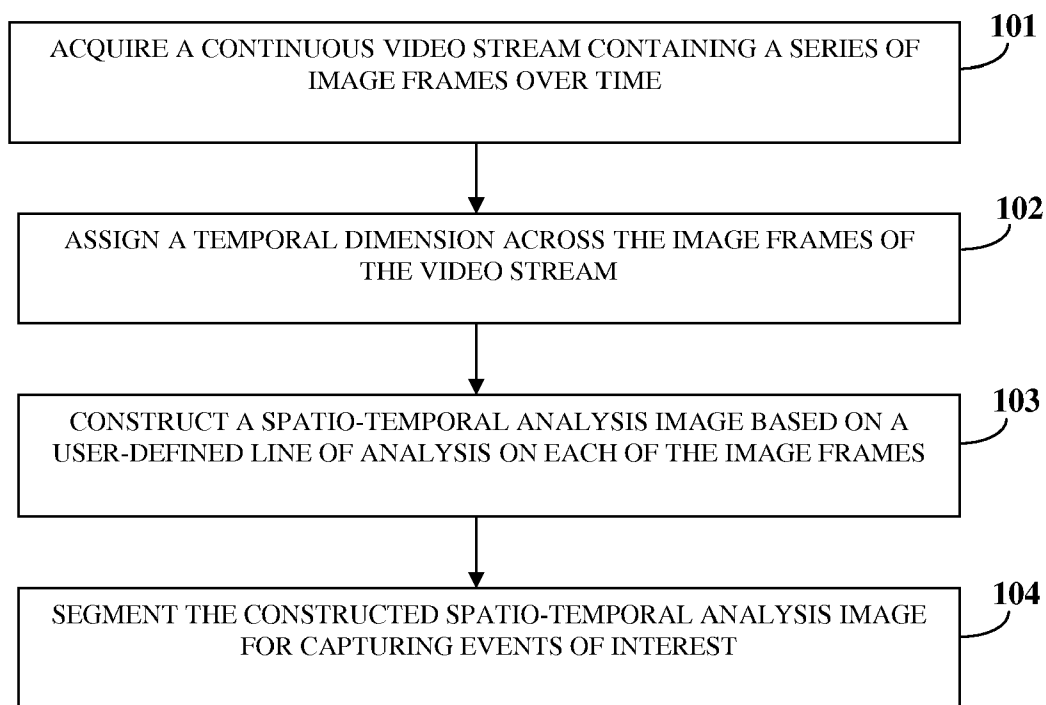

FIG. 1

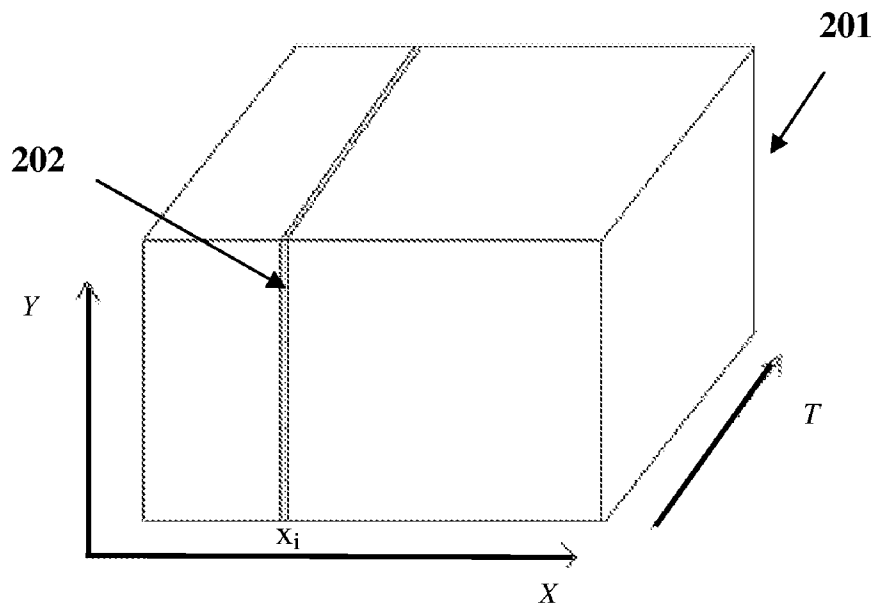

FIG. 2A

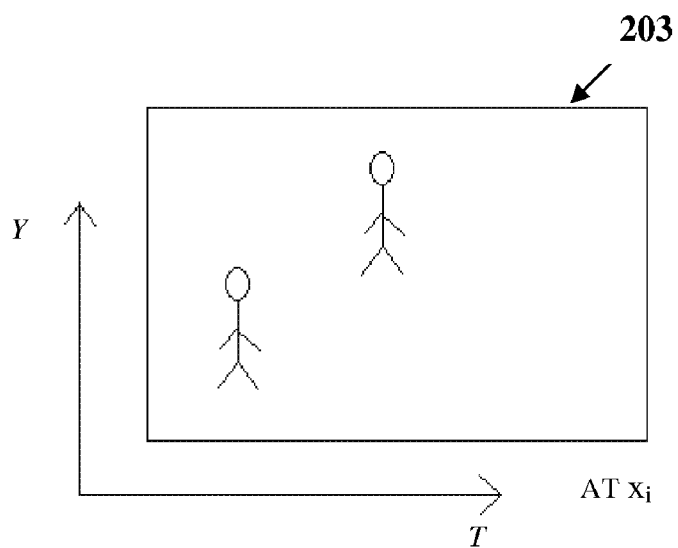

FIG. 2B

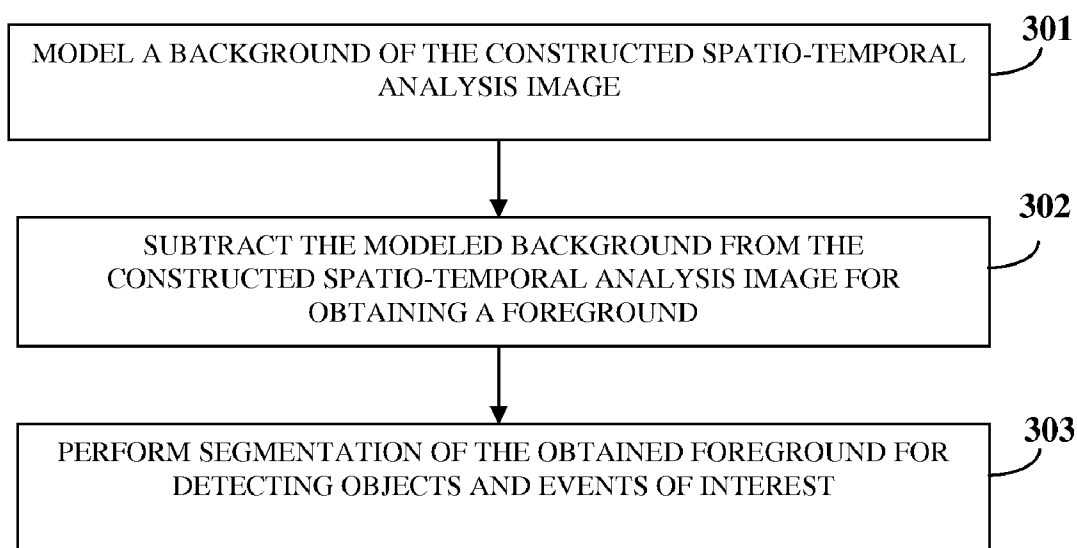

FIG. 3

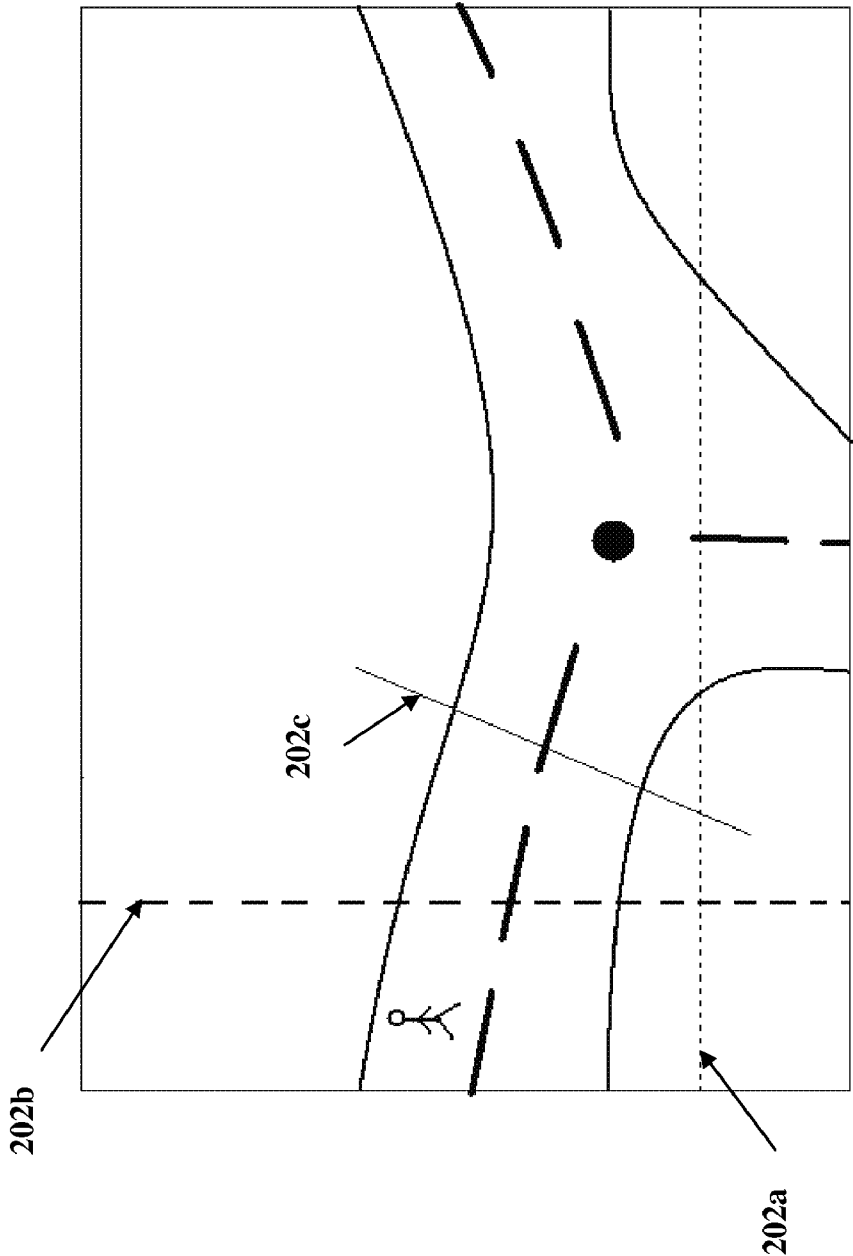

FIG. 4A

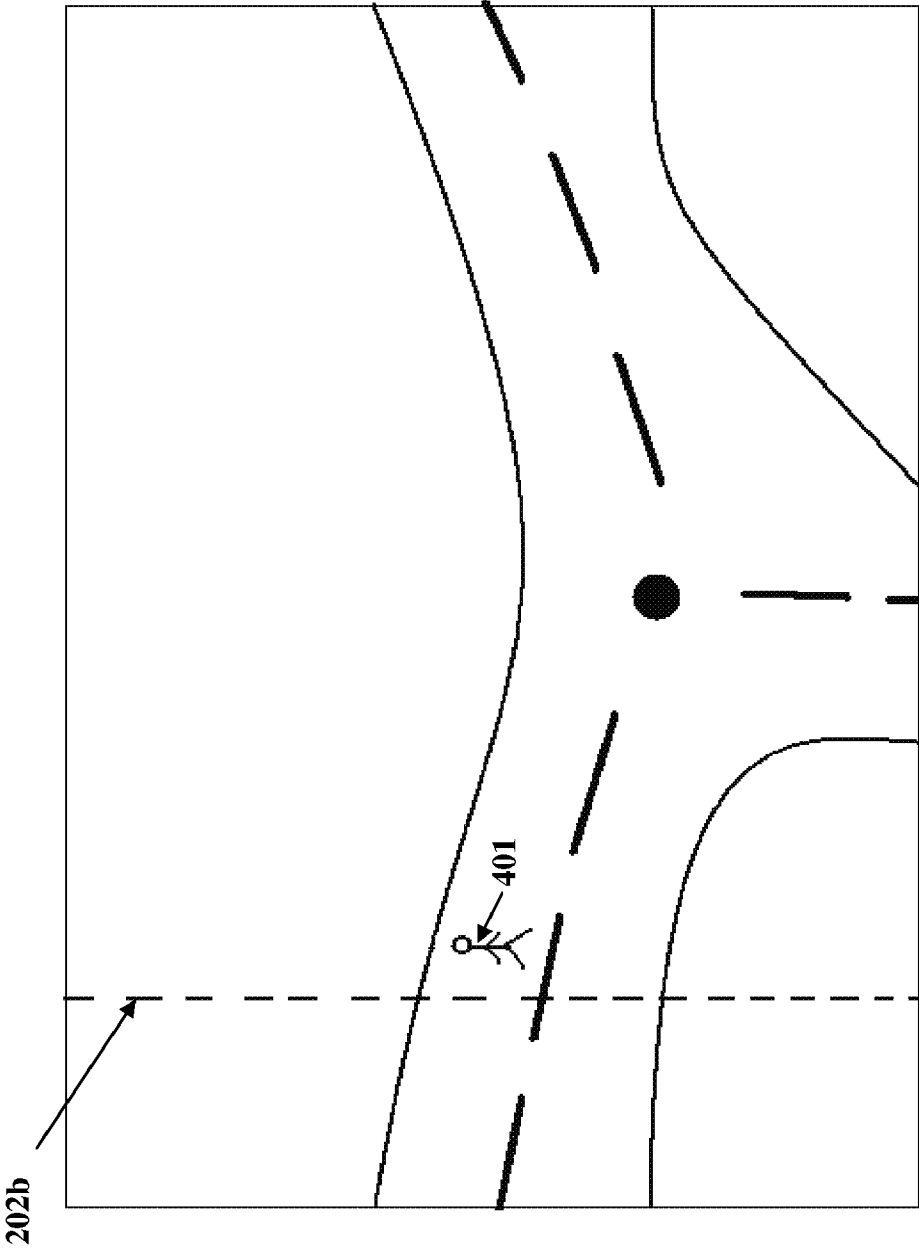

FIG. 4B

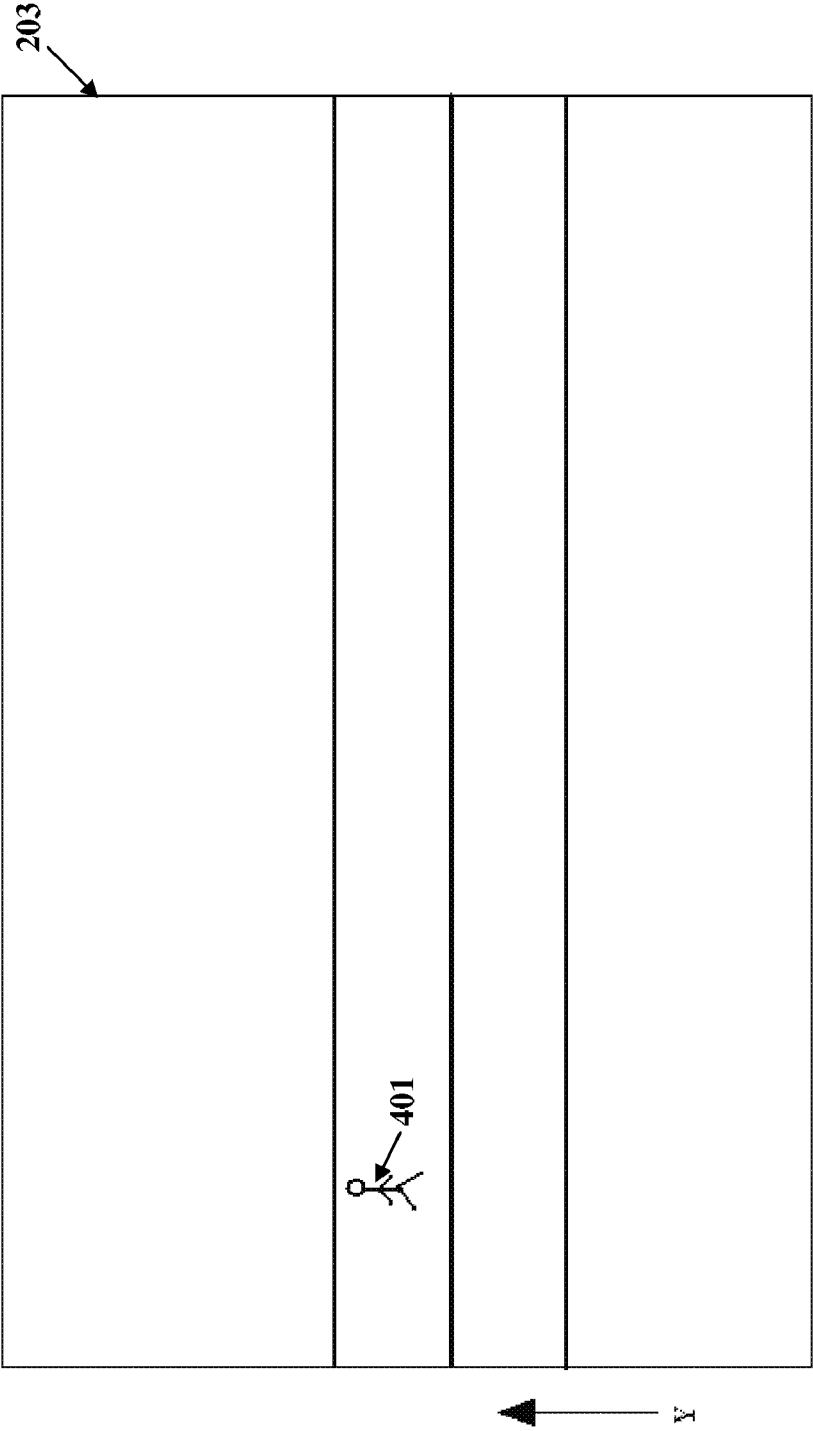

FIG. 4C

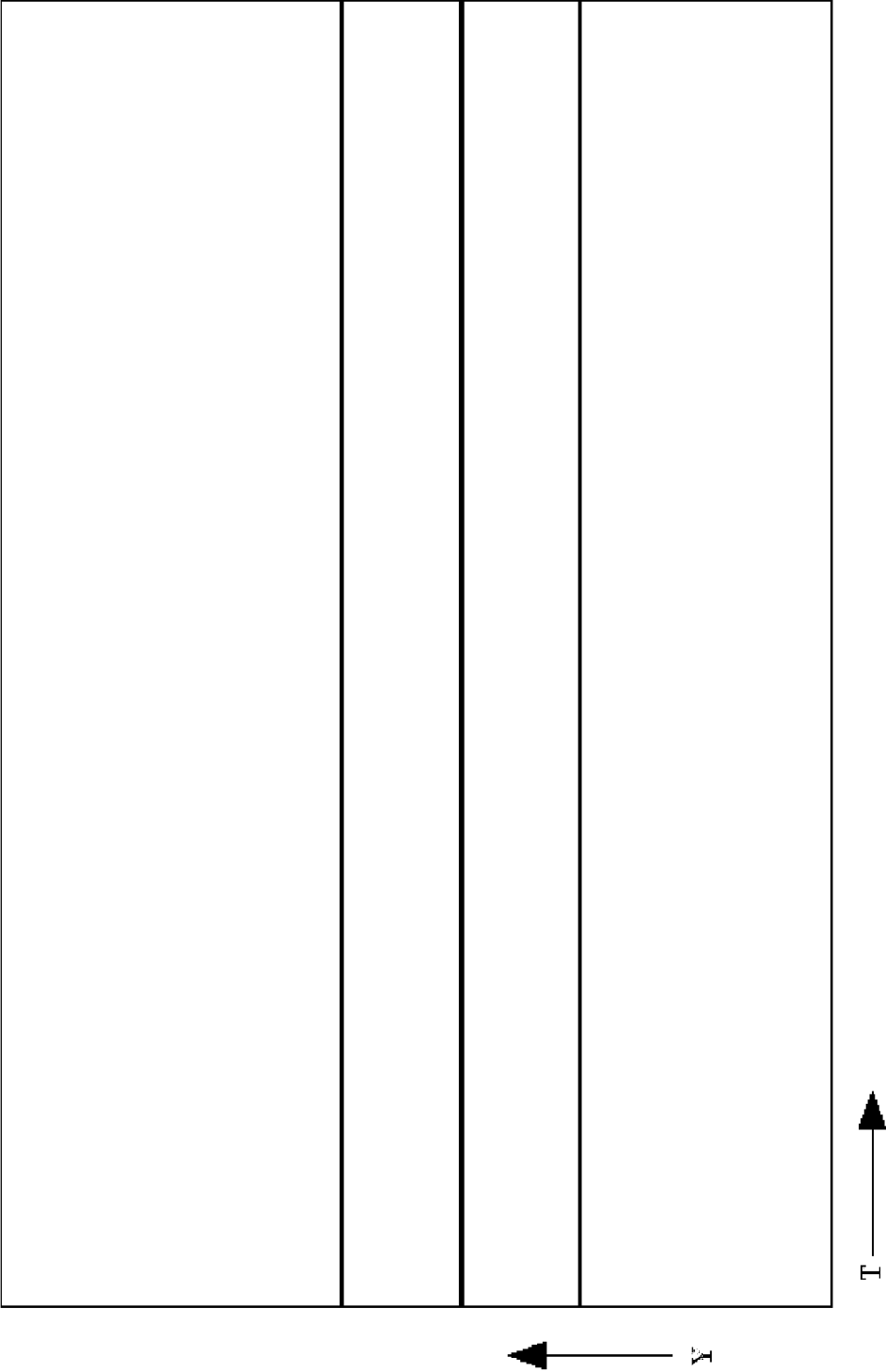
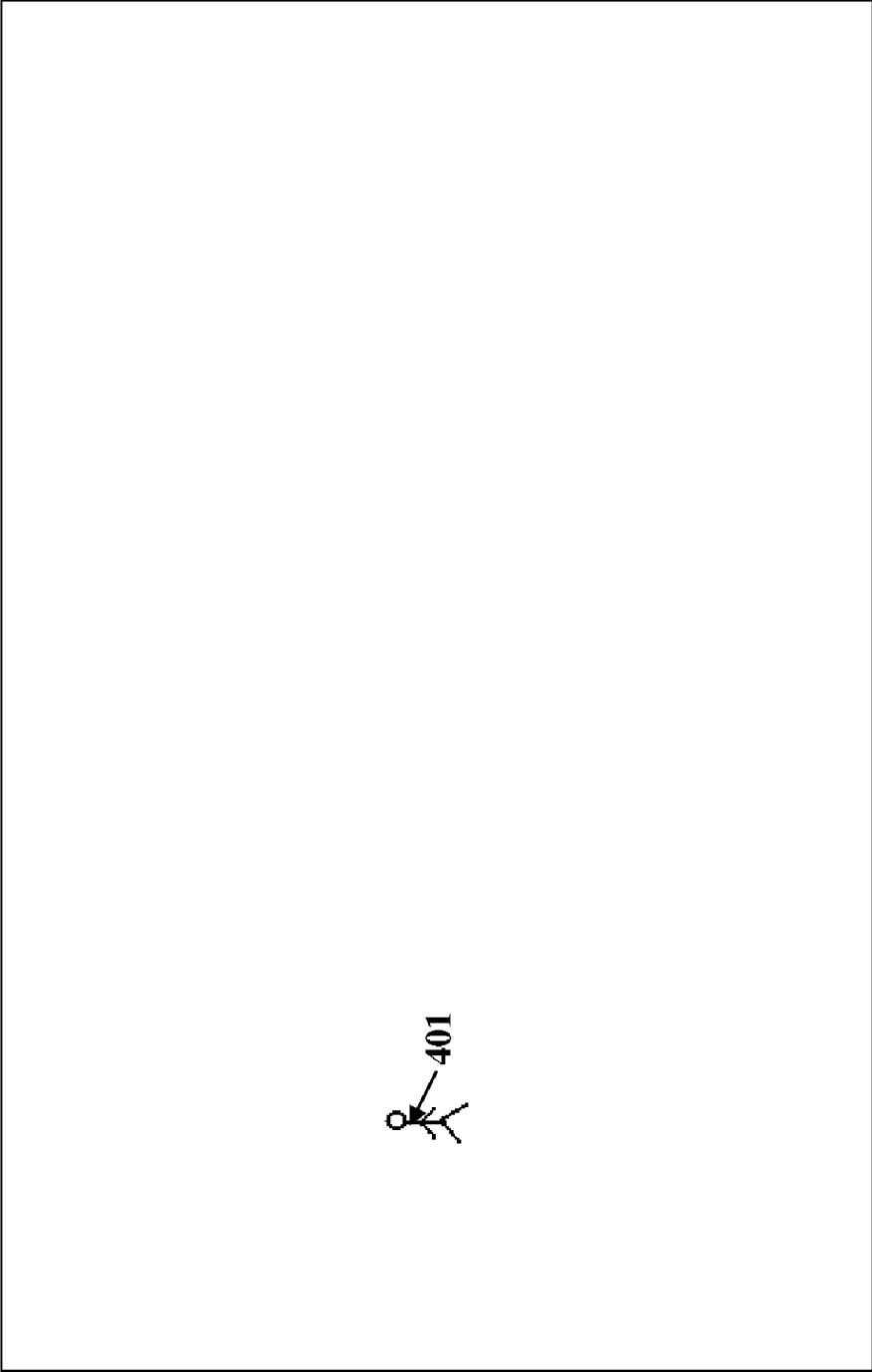

FIG. 4D



Y

T

FIG. 4E

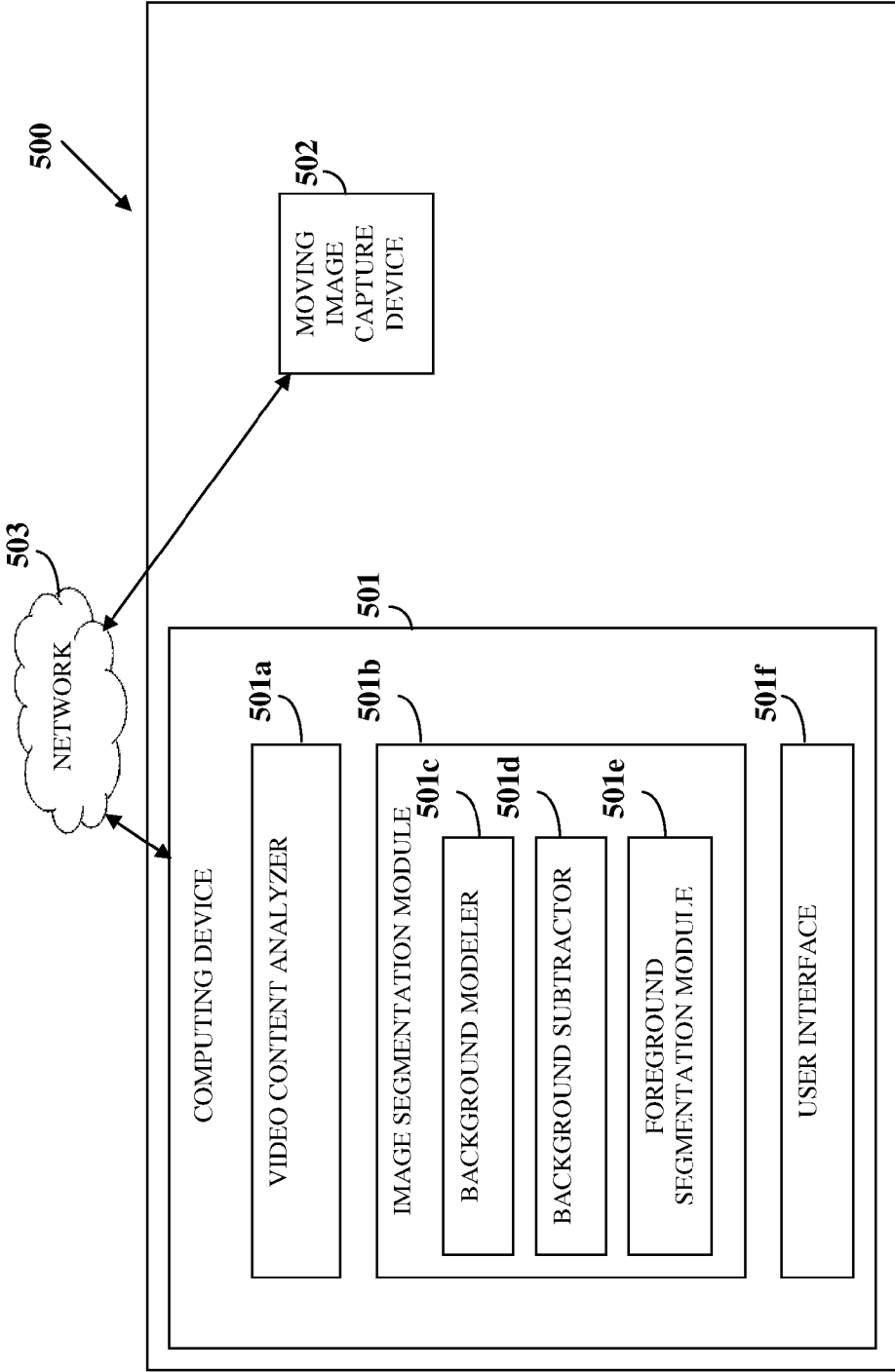

FIG. 5

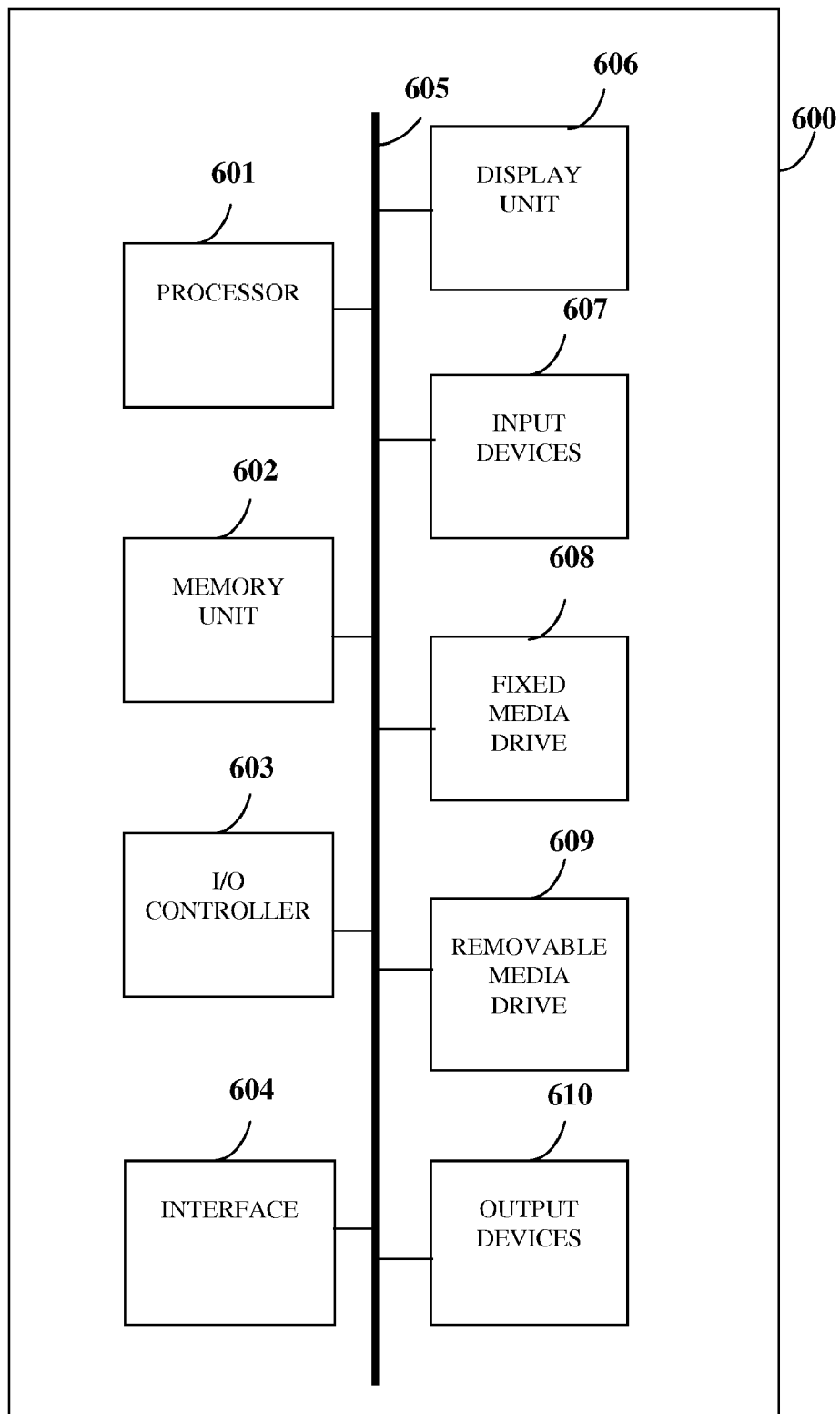

FIG. 6

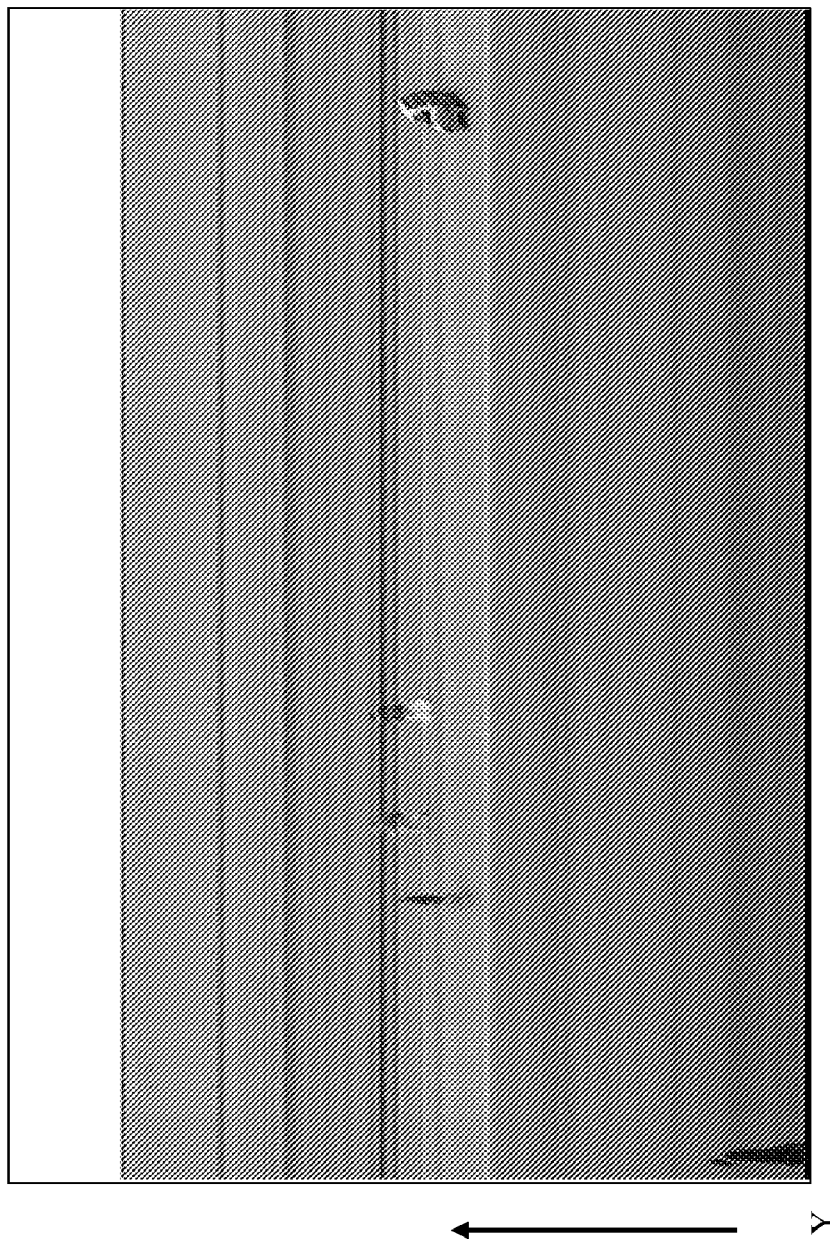

FIG. 7A

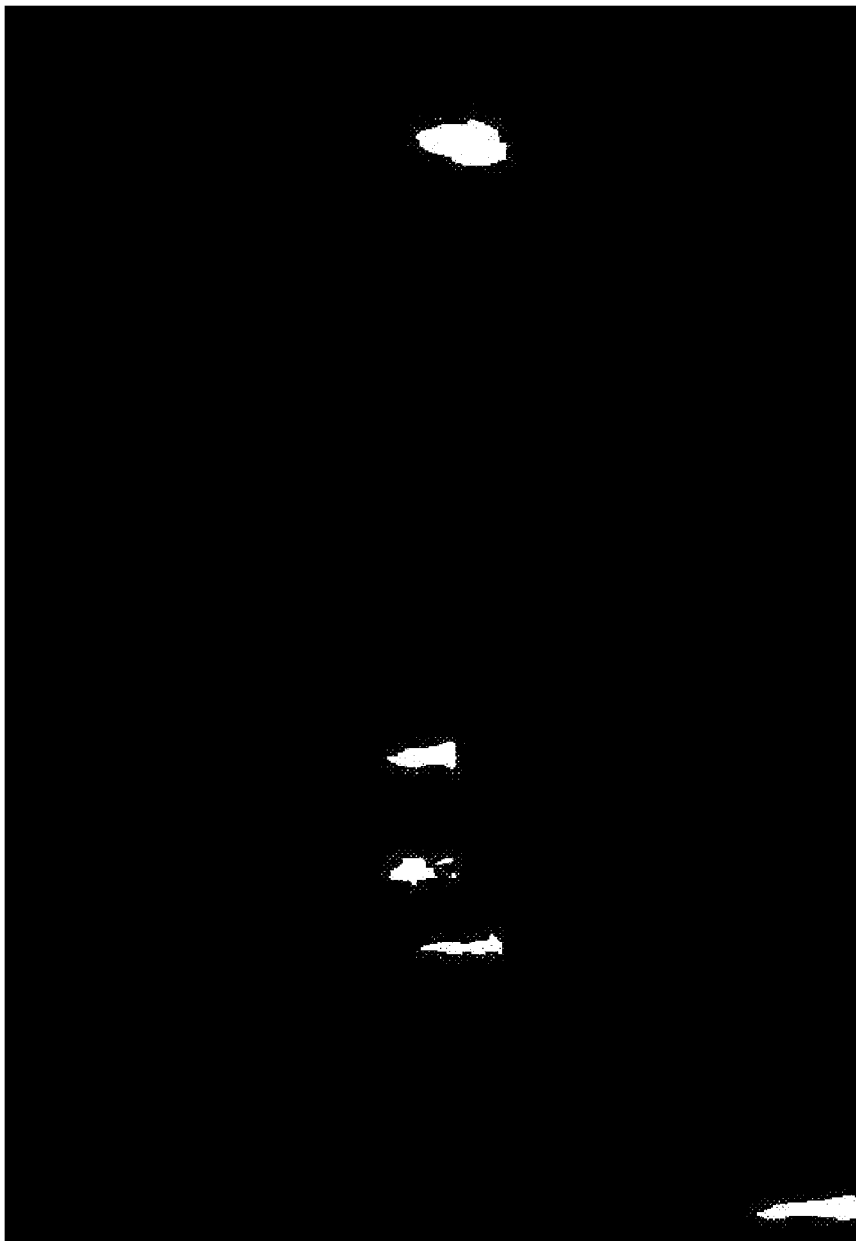

FIG. 7B

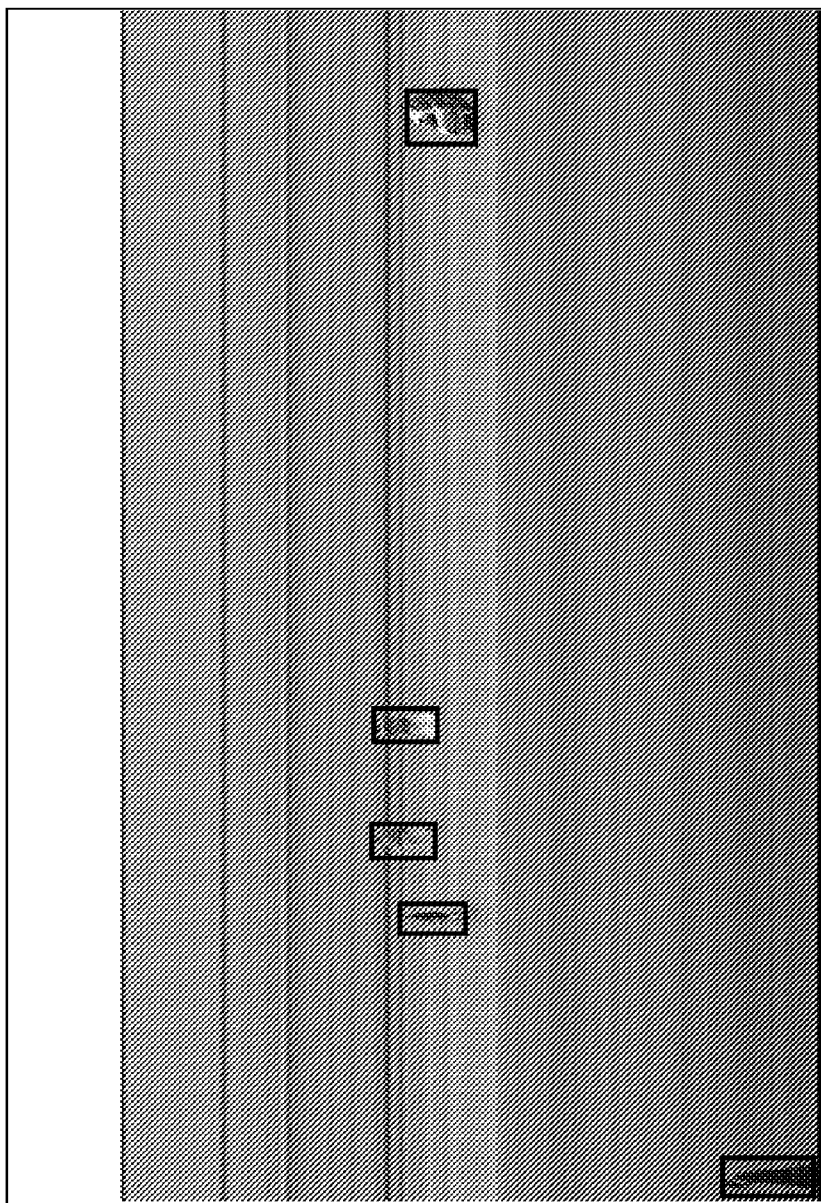

FIG. 7C

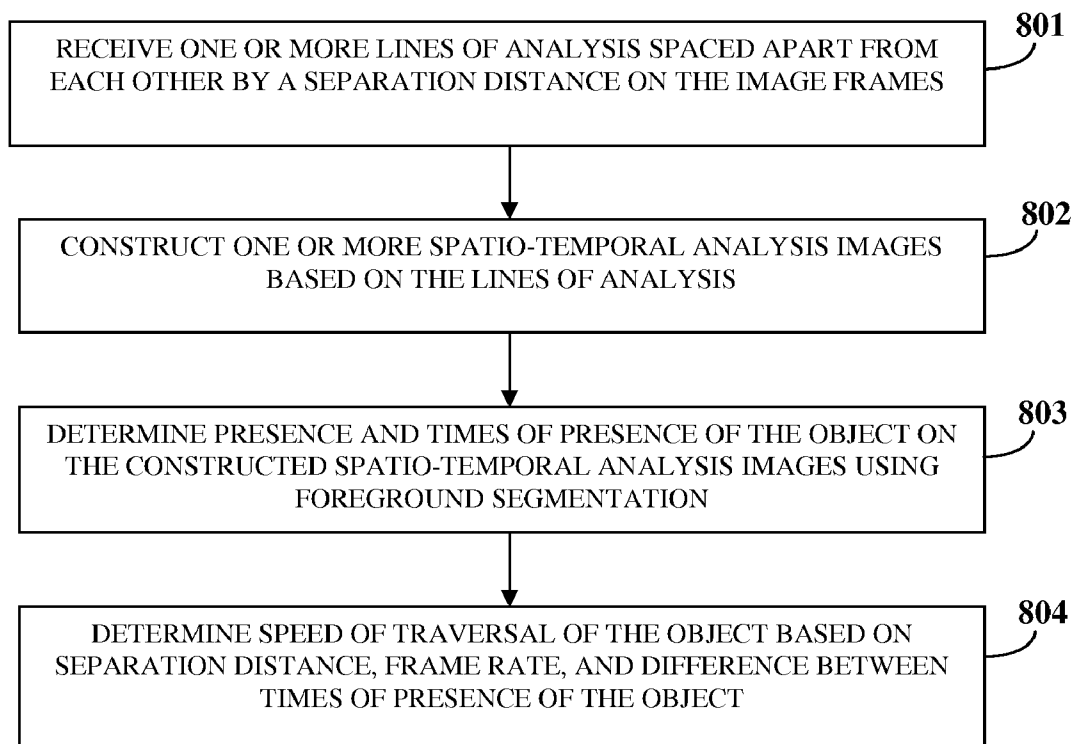

FIG. 8

**CAPTURING EVENTS OF INTEREST BY SPATIO-TEMPORAL VIDEO ANALYSIS**

**CROSS REFERENCE TO RELATED APPLICATIONS**

**[0001]** This application claims the benefit of non-provisional patent application number 1753/CHE/2010 titled "Capturing Events Of Interest By Spatio-temporal Video Analysis", filed on Jun. 23, 2010 in the Indian Patent Office.

**[0002]** The specification of the above referenced patent application is incorporated herein by reference in its entirety.

**BACKGROUND**

**[0003]** Video content analysis (VCA) refers to processing of video for determining events of interest and activity in a video, such as, a count of people or vehicles passing through a zone, the direction and speed of their movement, breach of boundary, speeding vehicles, etc. using computer vision techniques. VCA finds numerous applications in video surveillance, customer behavior in super markets, vehicular traffic analysis, and other areas. VCA is becoming a necessity given the extent of breach of security, requirement for surveillance, and threats to or potential compromise of human life and property in cities, defense establishments and at industrial and commercial premises.

**[0004]** Existing VCA algorithms process an entire image or a patch of the image using pure spatial image processing of the video. Hence, these algorithms are inherently suboptimal with respect to their computational efficiency and memory utilization. For example, processing visual graphics array (VGA) image frames of 640x480 pixels each in pure spatial domain requires segmentation of the entire 307200 pixels of each image frame, which is highly memory intensive.

**[0005]** Hence, there is a long felt but unresolved need for a computer implemented method and system for capturing events of interest by performing spatio-temporal analysis of a video using user-defined lines of analysis.

**SUMMARY OF THE INVENTION**

**[0006]** This summary is provided to introduce a selection of concepts in a simplified form that are further described in the detailed description of the invention. This summary is not intended to identify key or essential inventive concepts of the claimed subject matter, nor is it intended for determining the scope of the claimed subject matter.

**[0007]** The computer implemented method and system disclosed herein addresses the above stated need for capturing events of interest by optimally performing spatio-temporal analysis of a video using one or more user-defined lines of analysis. A continuous video stream containing a series of image frames is acquired over time. Each of the image frames is represented by horizontal spatial coordinates and vertical spatial coordinates of a two dimensional (2D) plane. A temporal dimension is assigned across the image frames of the video stream. The temporal dimension represents the order of the image frames using predefined temporal coordinates. A spatio-temporal analysis image is constructed based on a user-defined line of analysis on each of one or more of the image frames. The spatio-temporal analysis image is constructed by concatenating a series of temporally-successive linear pixel arrays along the temporal dimension. Each of the linear pixel arrays comprises an array of pixels selected along the line of analysis defined on each of one or more of the

image frames. For example, the spatio-temporal analysis image is constructed by concatenating linear pixel arrays from every Nth successive image frame in the series of image frames. The width of each of the linear pixel arrays is substantially identical to the width of the line of analysis. The line of analysis is, for example, at least a single pixel wide. The constructed spatio-temporal analysis image is segmented for capturing the events of interest. The constructed spatio-temporal analysis image provides a summary of events occurring over the image frames at the line of analysis for the duration of the video or the duration of the concatenation of the series of temporally-successive linear pixel arrays. A user can define one or more lines of analysis for parallelly constructing multiple spatio-temporal analysis images that are related in time.

**[0008]** The capture of the events of interest at the line of analysis comprises, for example, detecting presence of an object, detecting traversal of an object, determining speed of the traversal of the object, determining an object count based on the traversal of one or more objects, and determining duration of the presence of the object.

**[0009]** A user defines the line of analysis, having any orientation in the 2D plane, on one or more of the image frames. The user-inputted line of analysis on one of the image frames is used to automatically accumulate the linear pixel arrays from the remaining successive image frames by replicating the same coordinates of the line of analysis over these image frames. Accordingly, the line of analysis is defined by the horizontal spatial coordinates, or the vertical spatial coordinates, or by a combination of the horizontal spatial coordinates and the vertical spatial coordinates in each of the image frames. The constructed spatio-temporal analysis image is represented by a fixed spatial coordinate, a range of variable spatial coordinates, and variable temporal coordinates. For example, the constructed spatio-temporal analysis image is represented by a combination of a fixed horizontal spatial coordinate, a range of the vertical spatial coordinates and variable temporal coordinates, or a combination of a fixed vertical spatial coordinate, a range of the horizontal spatial coordinates and variable temporal coordinates.

**[0010]** The segmentation of the constructed spatio-temporal analysis image comprises foreground segmentation for detecting objects and the events of interest. A background of the constructed spatio-temporal analysis image is modeled, for example, by determining a moving average of the linear pixel arrays along the temporal dimension. The modeled background is subtracted from the constructed spatio-temporal analysis image for obtaining the foreground of the constructed spatio-temporal analysis image. Segmentation of the obtained foreground is then performed for detecting the objects and the events of interest.

**[0011]** Different events of interest are captured using the spatio-temporal analysis image based on the actual events occurring in the actual scenario being captured. One of the captured events is the speed of traversal of the object, for example, a moving vehicle. The speed of traversal of the object is determined by receiving one or more lines of analysis spaced apart from each other by a separation distance on the image frames from a user. The separation distance is based on an actual distance in the actual scene being captured. One or more spatio-temporal analysis images are constructed based on the lines of analysis. The presence and the times of presence of the object on the constructed spatio-temporal analysis images are determined using foreground segmentation. The speed of traversal of the object is determined based

on the separation distance, frame rate of the video, and difference between times of presence of the object on the constructed spatio-temporal analysis images.

#### BRIEF DESCRIPTION OF THE DRAWINGS

[0012] The foregoing summary, as well as the following detailed description of the invention, is better understood when read in conjunction with the appended drawings. For the purpose of illustrating the invention, exemplary constructions of the invention are shown in the drawings. However, the invention is not limited to the specific methods and instrumentalities disclosed herein.

[0013] FIG. 1 illustrates a computer implemented method for capturing events of interest by performing spatio-temporal analysis of a video.

[0014] FIG. 2A exemplarily illustrates a representation of a cube of image frames over time.

[0015] FIG. 2B exemplarily illustrates a spatio-temporal analysis image having spatial coordinates and temporal coordinates.

[0016] FIG. 3 exemplarily illustrates foreground segmentation of the spatio-temporal analysis image for detecting objects and events of interest.

[0017] FIG. 4A exemplarily illustrates sample user-defined lines of analysis in different inclinations.

[0018] FIG. 4B exemplarily illustrates a user-defined line of analysis intersecting elements in an image frame.

[0019] FIG. 4C exemplarily illustrates a spatio-temporal analysis image constructed based on the line of analysis depicted in FIG. 4B.

[0020] FIG. 4D exemplarily illustrates a modeled background of the spatio-temporal analysis image depicted in FIG. 4C.

[0021] FIG. 4E exemplarily illustrates a segmented foreground of the spatio-temporal analysis image depicted in FIG. 4C.

[0022] FIG. 5 illustrates a computer implemented system for capturing events of interest by performing a spatio-temporal analysis of a video.

[0023] FIG. 6 exemplarily illustrates the architecture of a computer system used for capturing events of interest by performing a spatio-temporal analysis of a video.

[0024] FIG. 7A exemplarily illustrates a screenshot of a spatio-temporal analysis image constructed based on a user-defined line of analysis.

[0025] FIG. 7B exemplarily illustrates a binary difference image of FIG. 7A.

[0026] FIG. 7C exemplarily illustrates foreground segmentation of the spatio-temporal analysis image of FIG. 7A.

[0027] FIG. 8 exemplarily illustrates a computer implemented method for determining speed of traversal of an object using spatio-temporal analysis of a video.

#### DETAILED DESCRIPTION OF THE INVENTION

[0028] FIG. 1 illustrates a computer implemented method for capturing events of interest by performing spatio-temporal analysis of a video. A continuous video stream containing a series of image frames is acquired **101** over time. Each of the image frames is represented by horizontal spatial coordinates (X) and vertical spatial coordinates (Y) of a two dimensional (2D) plane. A temporal dimension (T) is assigned **102** across the image frames of the video stream. The temporal dimension (T) represents the order of the image frames using pre-

defined temporal coordinates. A spatio-temporal analysis image is constructed **103** based on a user-defined line of analysis on each of one or more of the image frames. As used herein, the term "line of analysis" refers to a selection of a linear array of pixels in each moving image frame. The linear array of pixels in every line of analysis is sequentially accumulated over time in order to analyze and summarize events that are exposed only to the accumulated linear arrays of pixels. The width of each of the linear pixel arrays is substantially identical to the width of the line of analysis. The line of analysis is, for example, at least a single pixel wide. The spatio-temporal analysis image is constructed by concatenating a series of temporally-successive linear pixel arrays along the temporal dimension. Each of the linear pixel arrays comprises an array of pixels selected along the line of analysis defined on each of one or more of the image frames. For example, the spatio-temporal analysis image is constructed by concatenating linear pixel arrays from every Nth successive image frame in the series of image frames. The constructed spatio-temporal analysis image is segmented **104** for capturing the events of interest. The constructed spatio-temporal analysis image provides a summary of events occurring over the image frames at the line of analysis for the duration of the video or the duration of the concatenation of the series of temporally-successive linear pixel arrays. A user can define one or more lines of analysis for parallel construction of multiple spatio-temporal analysis images that are related in time.

[0029] The capture of events of interest at the line of analysis comprises, for example, detecting presence of an object, detecting traversal of the object, determining speed of the traversal of the object, determining an object count based on the traversal of one or more objects, determining duration of presence of the object, etc.

[0030] The user defines the line of analysis, having any in-plane orientation with respect to the two dimensional (2D) plane, on one or more of the image frames. The user-inputted line of analysis on one of the image frames is used to automatically accumulate the linear pixel arrays from the remaining successive image frames by replicating the same coordinates of the line of analysis over these image frames. Accordingly, the line of analysis is defined by the horizontal spatial coordinates or the vertical spatial coordinates, or by a combination of the horizontal spatial coordinates and the vertical spatial coordinates in one or more of the image frames. The constructed spatio-temporal analysis image is represented by a fixed spatial coordinate, a definite range of variable spatial coordinates and variable temporal coordinates. For example, the constructed spatio-temporal analysis image is represented by a combination of a fixed horizontal spatial coordinate, a range of vertical spatial coordinates and variable temporal coordinates, or a combination of a fixed vertical spatial coordinate, a range of horizontal spatial coordinates and variable temporal coordinates.

[0031] A normal static 2D image frame can be expressed as lines arranged horizontally or vertically such that each line is obtained from pixels  $P_{ij}$  at  $j=n$  for all values of  $i$  or  $i=m$  for all values of  $j$  to a maximum number of rows or columns. The static 2D image frame comprises pure spatial data in XY coordinates. Similarly, a video stream comprising 2D static image frames stacked in time (T) is visualized as a cube **201** of image frames, wherein the third dimension or the transverse dimension is time (T). FIG. 2A exemplarily illustrates a representation of a cube **201** of image frames over time. The

video stream can thus be visualized as an image cube **201** in XYT coordinates. A slice of the image cube **201** at a point on the X-axis, for example,  $x_i$  or on the Y-axis, for example,  $y_j$  over all values of time T, results in a reconstructed image that resembles a normal 2D static image, but reproduced in XT coordinates or YT coordinates. The line that intersects  $x_i$  for all values of Y and T, or the line that intersects  $y_j$  for all values of X and T is referred to as the “line of analysis” (LOA) **202**.

**[0032]** FIG. 2B exemplarily illustrates a spatio-temporal analysis image **203** having spatial and temporal coordinates. The spatio-temporal analysis image **203** exhibits certain visual characteristics that are interpreted to detect events of interest in any scenario. The relevant events of video surveillance, for example, perimeter breach, movement of objects, removal or addition of objects to a scene, etc., leaves a signature in space when captured and visualized over time (T). The spatio-temporal video content analysis (VCA) in XYT coordinates according to the computer implemented method disclosed herein extracts such signatures and performs pattern recognition over those signatures for detecting objects and events of interest.

**[0033]** Mathematically, each individual frame of the moving images is represented by  $I(y, x)$  and the video stream is represented by  $I(y, x, t)$ , where  $x$ ,  $y$  and  $t$  represent columns, rows and a time-axis, respectively, with the assumption that “ $x$ ” varies from 0 to N, “ $y$ ” varies from 0 to M, and “ $t$ ” varies from 0 to R. A user selects the line of analysis **202** by providing coordinates of the end points of the line **202** using a user interface, for example, a graphical user interface or a textual user interface. The user is presented with one of the image frames, for example,  $I(y, x, 3)$  which is the image frame at  $t=3$ , as exemplarily illustrated in FIG. 4A, on which the user selects the line of analysis (LOA) **202a**, **202b**, or **202c**. FIG. 4A exemplarily illustrates sample user-defined lines of analysis **202a**, **202b**, and **202c** in different in-plane inclinations with the respect to the 2D plane.

**[0034]** In an example, if the line of analysis **202a** is selected along row number 10 and entire “ $x$ ”, the resulting spatio-temporal analysis image **203** is given by  $I(10, x, t)$ , where “ $x$ ” varies from 0 to N, and “ $t$ ” varies from 0 to R. The values of “ $x$ ” can be specified by a range “ $x_1$ ” to “ $x_2$ ”, providing the image  $I(10, \beta, t)$ , where “ $\beta$ ” varies from  $x_1$  to  $x_2$ , and “ $t$ ” varies from 0 to R. In another example, if the line of analysis **202b** is selected along column number 23 and entire “ $y$ ”, the resulting spatio-temporal analysis image **203** is mathematically given by  $I(y, 23, t)$ , where “ $y$ ” varies from 0 to M, and “ $t$ ” varies from 0 to R. The values of “ $y$ ” can be specified within a range “ $y_1$ ” to “ $y_2$ ”, providing the image  $I(\alpha, 23, t)$ , where “ $\alpha$ ” varies from  $y_1$  to  $y_2$ , and “ $t$ ” varies from 0 to R. Similarly, for a line of analysis **202c** selected between any two points, at any inclination and length within the image resolution results in an spatio-temporal analysis image  $I(\alpha, \beta, t)$ , where  $(\alpha, \beta)$  specifies the points on the line of analysis **202c** varying between  $y$  and  $x$  values of the two end-points and “ $t$ ” varies from 0 to R. In an embodiment, the inclined linear arrays of pixels along the line of analysis **202c** from the image frames are re-arranged to form vertical lines on the spatio-temporal analysis image **203**, yielding a vertical, that is column, spatial axis and a horizontal, that is row, time axis. Alternatively, the inclined linear arrays of pixels along the line of analysis **202c** from the image frames are re-arranged to form horizontal lines on the spatio-temporal analysis image **203**, thereby yielding a horizontal spatial axis and a vertical time axis.

**[0035]** Consider an example where the user selects a vertical line of analysis **202b**, at a point on the  $x$ -axis, which varies over the entirety of the  $y$ -axis, that is, from 0 to M, as exemplarily illustrated in FIG. 4B. FIG. 4B exemplarily illustrates a user-defined line of analysis **202b** that intersects elements, for example, both sides of a street in the image frame. The array of pixels over this line of analysis **202b** is accumulated over time “ $t$ ”, for example, over 250 image frames for 10 seconds to construct a spatio-temporal analysis image **203** as exemplarily illustrated FIG. 4C. FIG. 4C exemplarily illustrates a spatio-temporal analysis image **203** constructed based on the line of analysis **202b** depicted in FIG. 4B. This spatio-temporal analysis image **203** is mathematically represented by a fixed horizontal spatial coordinate ( $x$ ), vertical variable coordinates ( $y$ ), for example,  $y_1$  to  $y_2$ , and variable temporal coordinates ( $t$ ). This spatio-temporal analysis image **203** has a resolution of  $L \times T$ , where “ $L$ ” is the length of the line of analysis **202b** and “ $T$ ” is the product of time of analysis in seconds and frame rate of the video.

**[0036]** FIG. 4C also illustrates three horizontal lines and a human object **401** on the spatio-temporal analysis image **203**. The three horizontal lines running along time “ $t$ ” appear in the spatio-temporal analysis image **203** due to the intersection of the line of analysis **202b** with the street borders and the street median. The human object **401** is reproduced in the spatio-temporal analysis image **203**, since the human object **401** crosses or moves across the line of analysis **202b**, exposing itself as a linear pixelled array on each image frame which are accumulated over time “ $t$ ”. The spatio-temporal analysis image **203** exemplarily illustrated in FIG. 4C is a summary of events occurring over 250 image frames or 10 seconds of the video along the line of analysis **202b**, and is used for visualization and segmentation for detecting events of interest.

**[0037]** A moving image capture device, for example, a closed-circuit television (CCTV) camera used for surveillance is mounted on rooftops or in tunneling toll booths and may be adapted for panning over a limited sweep angle or subjected to undue jitter. The linear array of pixels selected from each image frame based on the line of analysis **202** reproduces a specific section of the actual image captured at a single instance of time ( $t$ ). In an embodiment, where the camera is panning over a limited sweep angle, the coordinates of the line of analysis **202** may be dynamically shifted to continue to focus the analysis at a specific part of the actual scene. The coordinates of the line of analysis **202** may be dynamically shifted by obtaining the pan direction and pan magnitude during every transition from one image frame to another. Also, the coordinates of the line of analysis **202** may be dynamically shifted by obtaining the average pan direction and pan magnitude, or the velocity over a single sweep of the camera. This ensures that the linear array of pixels extracted from each successive image frame represents identical section or part of the actual scene, when the moving image capture device is panning over a limited sweep angle. This however requires that the focused part(s) of the scene always remains within the field of view of the camera. Where the camera may be subjected to a momentary jitter, a wider line of analysis **202** is used to compensate for the jitter. Additionally or alternatively, the spatio-temporal analysis image **203** may be constructed by concatenating linear pixel arrays from every Nth successive image frame, for example, every 3<sup>rd</sup> successive frame in the series of image frames, drowning out momentary fluctuations in the constructed spatio-temporal analysis image **203**.

**[0038]** FIG. 3 exemplarily illustrates foreground segmentation of the spatio-temporal analysis image 203 for detecting objects and events of interest. A background of the constructed spatio-temporal analysis image 203 is modeled 301, for example, by determining a moving average of the linear pixel arrays along the temporal dimension (t). The modeled background is subtracted 302 from the constructed spatio-temporal analysis image 203 for obtaining the foreground of the constructed spatio-temporal analysis image 203. The segmentation of the obtained foreground is performed 303 for detecting objects and events of interest.

**[0039]** The video content analysis of the spatio-temporal analysis image 203 using foreground segmentation may be performed using different techniques for background modeling and segmentation of the constructed spatio-temporal analysis image 203. The background modeling and segmentation according to the computer implemented method disclosed herein employs, for example, the moving average technique to determine the moving average of each vertical line of the spatio-temporal analysis image 203 of FIG. 4C. Each vertical line in the spatio-temporal analysis image 203 of FIG. 4C corresponds to the line of analysis 202 an image frame in the video at a specific instance of time, which is used to construct the spatio-temporal analysis image 203. Mathematically, the spatio-temporal analysis image 203 of FIG. 4C can be represented as follows:

$$I(y, \alpha, t);$$

**[0040]** where  $I(y, \alpha, t)$  is taken at  $x=\alpha$ , where  $\alpha$  is a value in the range of “x” between 0 to N, “y” varies from 0 to M and “t” varies from 0 to R.

**[0041]** The background of the spatio-temporal analysis image 203 is determined by applying a weighted moving average of the linear pixel arrays over time “t”. To begin with, the background of the image frame at “t0” corresponding to the linear pixel array in the spatio-temporal analysis image 203 at “t0” is modeled as follows:

$$B(y, \alpha, t0)=I(y, \alpha, t0);$$

**[0042]** Similarly,  $B(y, \alpha, t1)=I(y, \alpha, t1)*\delta+B(y, \alpha, t0)*(1-\delta)$ , where “ $\delta$ ” is a background adapting factor and is always  $0 \leq \delta \leq 1$ ; and “t0” and “t1” are the either absolute or relative time indices, representing the image frames from which the linear arrays of pixels are taken. “(y,  $\alpha$ , t1)” corresponds to the linear array taken at “ $\alpha$ ” column (LOA), for selected range of rows “y” on the image frame at time “t1”.  $B(y, \alpha, t0)$  is the background modeled at image frame “t0” and can be a line array with all zeros.  $B(y, \alpha, t1)$  is the background modeled at image frame “t1”. The background image, exemplarily illustrated in FIG. 4D, is generated by similarly modeling the background up to time tR, with the background being optionally modeled at each time instance (t0 to tR) in real time, as the spatio-temporal analysis image 203 is constructed.

**[0043]** The foreground is segmented by obtaining the absolute difference between the spatio-temporal analysis image 203 of FIG. 4C and the background image of FIG. 4D, and thresholding the differences. For example, segmentation on the spatio-temporal analysis image 203 at “t1” is performed by taking the absolute of the difference between  $I(y, \alpha, t1)$  and  $B(y, \alpha, t1)$ , and thresholding the difference as follows:

$$D(y, \alpha, t1)=1 \text{ if } |\text{absolute}(B(y, \alpha, t1)-I(y, \alpha, t1))| \geq \text{threshold};$$

$$D(y, \alpha, t1)=0 \text{ if } |\text{absolute}(B(y, \alpha, t1)-I(y, \alpha, t1))| < \text{threshold};$$

The segmented image  $SI(y, t)$  is obtained by accumulating  $D(y, \alpha, t0), D(y, \alpha, t1), D(y, \alpha, t2), \dots$  so on till  $D(y, \alpha, tR)$ , since “t” varies from 0 to R. The foreground segmented image  $SI(y, t)$  is illustrated in FIG. 4E.

**[0044]** The spatio-temporal or XYT analysis provides a background model using a single line of pixels as opposed to the conventional background models that process the entire image. Given a video graphics array (VGA) image of 640x480 pixels, the background modeling and segmentation according to the computer implemented method disclosed herein processes 480 pixels for analysis instead of the entire 307200 pixels. The line of analysis 202 is, for example, one pixel wide and hence precludes any duplication of objects, unless the objects cross the line of analysis 202 more than once. The spatio-temporal analysis for video content is, for example, used for people or vehicle count with better accuracy. The XYT analysis summarizes the video of a few gigabytes (GB) for monitoring a highway, a tollgate, an entrance to an office, or an industry or commercial premises, etc., in a few megabytes (MB) of memory. The spatio-temporal analysis image 203 is used for visualization, with each line along the time axis (t) of the spatio-temporal analysis image 203 specifying the unit of time that is used for time indexing for navigating through the video.

**[0045]** The spatio-temporal analysis image 203 constructed by the spatio-temporal analysis of the video exhibits a few notable unique characteristics. For example, if an object remains stationary on the line of analysis 202, the reproduction of the object in the spatio-temporal analysis image appears stretched or elongated along the temporal dimension (t). On the other hand, if an object traverses the line of analysis 202 at a high speed, the object appears compressed in the spatio-temporal analysis image. The spatio-temporal analysis according to the computer implemented method disclosed herein is a valuable technique to summarize an entire day’s traffic at a toll gate and the shopper traffic at the entrance of a mall, to determine traffic line violations, the speed of vehicles, perimeter breach in a mining area, industrial or commercial campuses, etc.

**[0046]** FIG. 5 illustrates a computer implemented system 500 for capturing events of interest by performing a spatio-temporal analysis of a video. The computer implemented system 500 disclosed herein comprises a moving image capture device 502 and a computing device 501. The computing device 501 of the computer implemented system 500 disclosed herein comprises a video content analyzer 501a, an image segmentation module 501b, and a user interface 501f. The moving image capture device 502, for example, a surveillance camera acquires a continuous video stream containing a series of image frames over time. Each of the image frames is represented by horizontal spatial coordinates and vertical spatial coordinates of a two dimensional plane. The moving image capture device 502 may be connected to a network 503, for example, a local area network to transfer the acquired moving images over the network 503 to the computing device 501. In an embodiment, the moving device capture device 502 is connected to the computing device 501 via serial and parallel communication ports, for example, using a universal serial bus (USB) specification. In another embodiment, the moving image capture device 502 may comprise a dedicated processor and memory for installing and executing the video content analyzer 501a, the image segmentation module 501b, and the user interface 501f.

[0047] The video content analyzer **501a** provided on the computing device **501** assigns a temporal dimension across the image frames of the video stream. The temporal dimension represents the order of the image frames using pre-defined temporal coordinates. The video content analyzer **501a** constructs a spatio-temporal analysis image **203** based on a user-defined line of analysis **202** on each of the image frames. The video content analyzer **501a** constructs the spatio-temporal analysis image **203** by concatenating a series of temporally-successive linear pixel arrays along the temporal dimension. Each of the linear pixel arrays comprises an array of pixels underlying the line of analysis **202** defined on each of the image frames. The image segmentation module **501b** on the computing device **501** segments the constructed spatio-temporal analysis image **203** for capturing the events of interest.

[0048] The user interface **501f**, for example, a graphical user interface or a textual user interface on the computing device **501** renders one or more image frames of a stored video or a live video to the user. The user interface **501f** enables the user to define the line of analysis **202**, having any in-plane orientation, length and width, on the image frames. In an embodiment, the user interface **501f** enables the user to define one or more lines of analysis **202** for parallelly constructing multiple spatio-temporal analysis images. The constructed spatio-temporal analysis image **203** provides a summary of events occurring over the image frames at the line of analysis **202** for the duration of the video or the duration of the concatenation of the series of temporally-successive linear pixel arrays. The spatio-temporal analysis image **203** is represented by, for example, a combination of a fixed horizontal spatial coordinate, a range of the vertical spatial coordinates, and variable temporal coordinates, or a combination of a fixed vertical spatial coordinate, a range of the horizontal spatial coordinates, and variable temporal coordinates.

[0049] The image segmentation module **501b** performs foreground segmentation of the constructed spatio-temporal analysis image **203** for detecting objects and events of interest. The image segmentation module **501b** comprises a background modeler **501c**, a background subtractor **501d**, and a foreground segmentation module **501e**. The background modeler **501c** models the background of the constructed spatio-temporal analysis image **203**, for example, by determining a moving average of the linear pixel arrays along the temporal dimension. The background subtractor **501d** subtracts the modeled background from the constructed spatio-temporal analysis image **203** by obtaining the absolute difference between the constructed spatio-temporal analysis image **203** and the modeled background for obtaining foreground of the spatio-temporal analysis image **203**. The foreground segmentation module **501e** performs segmentation of the obtained foreground for detecting objects and events of interest, for example, presence of an object, traversal of the object, speed of traversal of the object, an object count based on the traversal of one or more objects, duration of the presence of an object, etc.

[0050] FIG. 6 exemplarily illustrates the architecture of a computer system **600** used for capturing events of interest by performing a spatio-temporal analysis of a video. The computer system **600** comprises a processor **601**, a memory unit **602** for storing programs and data, an input/output (I/O) controller **603**, and a display unit **606** communicating via a data bus **605**. The memory unit **602** comprises a random access memory (RAM) and a read only memory (ROM). The

computer system **600** comprises one or more input devices **607**, for example, a keyboard such as an alphanumeric keyboard, a mouse, a joystick, etc. The input/output (I/O) controller **603** controls the input and output actions performed by a user. The computer system **600** communicates with other computer systems through an interface **604**, for example, a Bluetooth™ interface, an infrared (IR) interface, a WiFi interface, a universal serial bus interface (USB), a local area network (LAN) or wide area network (WAN) interface, etc.

[0051] The processor **601** is an electronic circuit that can execute computer programs. The memory unit **602** is used for storing programs, applications, and data. For example, the video content analyzer **501a** and the image segmentation module **501b** are stored on the memory unit **602** of the computer system **600**. The memory unit **602** is, for example, a random access memory (RAM) or another type of dynamic storage device that stores information and instructions for execution by processor **601**. The memory unit **602** also stores temporary variables and other intermediate information used during execution of the instructions by the processor **601**. The computer system **600** further comprises a read only memory (ROM) or another type of static storage device that stores static information and instructions for the processor **601**. The data bus **605** permits communication between the modules, for example, **501a**, **501b**, **501c**, **501d**, **501e**, and **501f** of the computer implemented system **500** disclosed herein.

[0052] Computer applications and programs are used for operating the computer system **600**. The programs are loaded onto the fixed media drive **608** and into the memory unit **602** of the computer system **600** via the removable media drive **609**. In an embodiment, the computer applications and programs may be loaded directly through the network **503**. Computer applications and programs are executed by double clicking a related icon displayed on the display unit **606** using one of the input devices **607**. The user interacts with the computer system **600** using a user interface **501f** of the display unit **606**. The user selects the line of analysis **202** of any orientation, size, and thickness on one or more image frames on the user interface **501f** of the display unit **606** using one of the input devices **607**, for example, a computer mouse.

[0053] The computer system **600** employs an operating system for performing multiple tasks. The operating system manages execution of, for example, the video content analyzer **501a** and the image segmentation module **501b** provided on the computer system **600**. The operating system further manages security of the computer system **600**, peripheral devices connected to the computer system **600**, and network connections. The operating system employed on the computer system **600** recognizes keyboard inputs of a user, output display, files and directories stored locally on the fixed media drive **608**, for example, a hard drive. Different programs, for example, a web browser, an e-mail application, etc., initiated by the user are executed by the operating system with the help of the processor **601**, for example, a central processing unit (CPU). The operating system monitors the use of the processor **601**.

[0054] The video content analyzer **501a** and the image segmentation module **501b** are installed in the computer system **600** and the instructions are stored in the memory unit **602**. The captured moving images are transferred from the moving image capture device **502** to the video content analyzer **501a** installed in the computer system **600** of the computing device **501** via the interface **604** or a network **503**. A user initiates the execution of the video content analyzer **501a**

by double clicking the icon for the video content analyzer **501a** on the display unit **606** or the execution of the video content analyzer **501a** is automatically initiated on installing the video content analyzer **501a** on the computing device **501**. Instructions for capturing events of interest by performing spatio-temporal analysis of the video are retrieved by the processor **601** from the program memory in the form of signals. The locations of the instructions from the modules, for example, **501a**, **501b**, **501c**, **501d**, and **501e**, are determined by a program counter (PC). The program counter stores a number that identifies the current position in the program of the video content analyzer **501a** and the image segmentation module **501b**.

[0055] The instructions fetched by the processor **601** from the program memory after being processed are decoded. The instructions are placed in an instruction register (IR) in the processor **601**. After processing and decoding, the processor **601** executes the instructions. For example, the video content analyzer **501a** defines instructions for assigning a temporal dimension across the image frames of the video stream. The video content analyzer **501a** further defines instructions for constructing a spatio-temporal analysis image **203** based on a user-defined line of analysis **202** on each of the image frames. The image segmentation module **501b** defines instructions for segmenting the constructed spatio-temporal analysis image **203** for capturing the events of interest. The background modeler **501c** defines instructions for modeling the background of the constructed spatio-temporal analysis image **203**. The background subtractor **501d** defines instructions for subtracting the modeled background from the constructed spatio-temporal analysis image **203** for obtaining the foreground of the constructed spatio-temporal analysis image **203**. The foreground segmentation module **501e** defines instructions for performing segmentation of the obtained foreground for detecting objects and events of interest. The instructions are stored in the program memory or received from a remote server.

[0056] The processor **601** retrieves the instructions defined by the video content analyzer **501a**, the image segmentation module **501b**, the background modeler **501c**, the background subtractor **501d**, and the foreground segmentation sub-module **501e**, and executes the instructions.

[0057] At the time of execution, the instructions stored in the instruction register are examined to determine the operations to be performed. The specified operation is then performed by the processor **601**. The operations include arithmetic and logic operations. The operating system performs multiple routines for performing a number of tasks required to assign input devices **607**, output devices **610**, and memory for execution of the video content analyzer **501a** and the image segmentation module **501b**. The tasks performed by the operating system comprise assigning memory to the video content analyzer **501a**, the image segmentation module **501b** and data, moving data between the memory **602** and disk units and handling input/output operations. The operating system performs the tasks on request by the operations and after performing the tasks, the operating system transfers the execution control back to the processor **601**. The processor **601** continues the execution to obtain one or more outputs. The outputs of the execution of the video content analyzer **501a** and the image segmentation module **501b** are displayed to the user on the display unit **606**.

[0058] FIG. 7A exemplarily illustrates a screenshot of a spatio-temporal analysis image constructed based on a user-

defined line of analysis **202**. As illustrated in FIG. 7A, the spatio-temporal analysis image is constructed based on a vertical line of analysis **202b** selected at a point on the x-axis ( $X_i$ ), which varies over the entirety of the y-axis. FIG. 7B exemplarily illustrates a binary difference image of FIG. 7A. FIG. 7C exemplarily illustrates foreground segmentation of the spatio-temporal analysis image of FIG. 7A. The foreground segmentation reveals that four pedestrians and a vehicle have passed the line of analysis **202b** over a finite time period  $T$  of the video being analyzed.

[0059] The spatio-temporal analysis of a video also referred to as “video content analysis” according to the computer implemented method and system **500** disclosed herein for constructing and segmenting the spatio-temporal analysis image provides different video content analysis applications for monitoring and surveillance in different scenarios. A few applications in different scenarios are disclosed herein. The spatio-temporal analysis is used to determine a count of people over a predetermined duration. The people count is determined by the count of foreground objects in the spatio-temporal analysis image. The spatio-temporal analysis image is constructed by accumulating the linear pixels arrays from the image frames of the video, based on the line of analysis **202**, over the predetermined duration. In this case, the line of analysis **202** is defined across a doorway, a passageway, or a corridor dominated by incoming and outgoing people.

[0060] In another scenario, where the line of analysis **202** is selected to depict a perimeter line, the spatio-temporal analysis at the line of analysis **202** is used to detect a perimeter breach or simulate a tripwire. When an object crosses the line of analysis **202**, the object is reproduced in the spatio-temporal analysis image **203**, as illustrated in FIG. 4C. The spatio-temporal analysis image is generated over time and segmented to determine the number of perimeter breaches and the time of perimeter breaches.

[0061] In another scenario, the speed of traversal of the object, for example, a moving vehicle is determined using one or more spatio-temporal analysis images. FIG. 8 exemplarily illustrates a computer implemented method for determining speed of traversal of an object using spatio-temporal analysis of a video. The speed of an object is determined by receiving **801** one or more lines of analysis **202**, for example, at  $X_i$  and  $X_k$  spaced apart from each other by a separation distance on the image frames from a user. The separation distance is based on an actual distance in the actual scene being captured. One or more spatio-temporal analysis images are constructed **802** based on the lines of analysis **202**. The presence and the times of presence of the object on the constructed spatio-temporal analysis images, for example,  $X_iYT$  and  $X_kYT$  are determined **803** using foreground segmentation disclosed in the detailed description of FIG. 3. The speed of traversal of the object is determined **804** based on the separation distance, frame rate of the video and difference between times of presence of the object on the constructed spatio-temporal analysis images.

[0062] Other applications based on similar principles include, for example, determining the winner in a track race. In this case, the line of analysis **202** is defined along the finish line of a track. A spatio-temporal analysis image is constructed based on the line of analysis **202** to determine the race winner based on the time of appearance of the participants or athletes on the spatio-temporal analysis image. The spatio-temporal analysis disclosed herein also enables automated parking lot management. The length of the stretch or

elongation of an object, for example, a stationary vehicle on the spatio-temporal analysis image provides the parking duration of the stationary vehicle. The line of analysis **202** is defined within the parking slot with a suitable orientation and length. In the same way, the vacant slots in a parking lot are determined by considering the binary difference image of the spatio-temporal (XYT) image of the parking lot. For example, white patches on the binary difference image correspond to occupied slots, while black patches correspond to the unoccupied slots. In road traffic management, where video monitoring is installed in the area around traffic lights and intersections, the line of analysis **202** is suitably defined along the road markings to enable video content analysis. At an unmanned railway crossing installed with video surveillance, the line of analysis **202** is defined along the rail track for video content analysis. In a museum with video surveillance for monitoring exhibits such as paintings or statues, video content analysis is performed at specific parts of the scene by defining the line of analysis **202** at those parts.

**[0063]** The events of interest in a scene may be specific to the application scenario and requirement, and the general arrangement or landscape of the captured scene. A person of ordinary skill in the art or any user in the monitoring and surveillance domain can easily recognize parts of a scene that require content analysis, and accordingly define one or more lines of analysis **202** on one or more image frames, including the orientation, length and width of the lines of analysis **202**, for performing spatio-temporal analysis.

**[0064]** It will be readily apparent that the various methods and algorithms described herein may be implemented in a computer readable medium appropriately programmed for general purpose computers and computing devices. Typically a processor, for example, one or more microprocessors will receive instructions from a memory or like device, and execute those instructions, thereby performing one or more processes defined by those instructions. Further, programs that implement such methods and algorithms may be stored and transmitted using a variety of media, for example, computer readable media in a number of manners. In one embodiment, hard-wired circuitry or custom hardware may be used in place of, or in combination with, software instructions for implementation of the processes of various embodiments. Thus, embodiments are not limited to any specific combination of hardware and software. A "processor" means any one or more microprocessors, central processing unit (CPU) devices, computing devices, microcontrollers, digital signal processors or like devices. The term "computer readable medium" refers to any medium that participates in providing data, for example instructions that may be read by a computer, a processor or a like device. Such a medium may take many forms, including but not limited to, non-volatile media, volatile media, and transmission media. Non-volatile media include, for example, optical or magnetic disks and other persistent memory volatile media include dynamic random access memory (DRAM), which typically constitutes the main memory. Transmission media include coaxial cables, copper wire and fiber optics, including the wires that comprise a system bus coupled to the processor. Common forms of computer readable media include, for example, a floppy disk, a flexible disk, hard disk, magnetic tape, any other magnetic medium, a compact disc-read only memory (CD-ROM), digital versatile disc (DVD), any other optical medium, punch cards, paper tape, any other physical medium with patterns of holes, a random access memory (RAM), a

programmable read only memory (PROM), an erasable programmable read only memory (EPROM), an electrically erasable programmable read only memory (EEPROM), a flash memory, any other memory chip or cartridge, a carrier wave as described hereinafter, or any other medium from which a computer can read. In general, the computer readable programs may be implemented in any programming language. Some examples of languages that can be used include C, C++, C#, Perl, Python, or JAVA. The software programs may be stored on or in one or more mediums as an object code. A computer program product comprising computer executable instructions embodied in a computer readable medium comprises computer parsable codes for the implementation of the processes of various embodiments.

**[0065]** The present invention can be configured to work in a network environment including a computer that is in communication, via a communications network, with one or more devices. The computer may communicate with the devices directly or indirectly, via a wired or wireless medium such as the Internet, a local area network (LAN), a wide area network (WAN) or the Ethernet, token ring, or via any appropriate communications means or combination of communications means. Each of the devices may comprise computers, such as those based on the Intel® processors, AMD® processors, UltraSPARC® processors, Sun® processors, IBM® processors, etc. that are adapted to communicate with the computer. Any number and type of machines may be in communication with the computer.

**[0066]** The foregoing examples have been provided merely for the purpose of explanation and are in no way to be construed as limiting of the present invention disclosed herein. While the invention has been described with reference to various embodiments, it is understood that the words, which have been used herein, are words of description and illustration, rather than words of limitation. Further, although the invention has been described herein with reference to particular means, materials and embodiments, the invention is not intended to be limited to the particulars disclosed herein; rather, the invention extends to all functionally equivalent structures, methods and uses, such as are within the scope of the appended claims. Those skilled in the art, having the benefit of the teachings of this specification, may effect numerous modifications thereto and changes may be made without departing from the scope and spirit of the invention in its aspects.

We claim:

**1.** A computer implemented method for capturing events of interest by performing a spatio-temporal analysis of a video, comprising:

acquiring a continuous video stream containing a series of image frames over time, wherein each of said image frames is represented by horizontal spatial coordinates and vertical spatial coordinates of a two dimensional plane;

assigning a temporal dimension across said image frames of said video stream, wherein said temporal dimension represents order of said image frames using predefined temporal coordinates;

constructing a spatio-temporal analysis image based on a user-defined line of analysis on each of one or more of said image frames, wherein said spatio-temporal analysis image is constructed by concatenating a series of temporally-successive linear pixel arrays along said temporal dimension, each of said linear pixel arrays

comprising an array of pixels along said line of analysis defined on said each of said one or more of said image frames; and

segmenting said constructed spatio-temporal analysis image for capturing said events of interest.

2. The computer implemented method of claim 1, further comprising defining said line of analysis along one or more of said horizontal spatial coordinates, said vertical spatial coordinates, and a combination of said horizontal spatial coordinates and said vertical spatial coordinates in one or more of said image frames, by a user.

3. The computer implemented method of claim 1, wherein said constructed spatio-temporal analysis image is represented by one of a combination of a fixed horizontal spatial coordinate, a range of said vertical spatial coordinates and variable temporal coordinates, and a combination of a fixed vertical spatial coordinate, a range of said horizontal spatial coordinates and variable temporal coordinates.

4. The computer implemented method of claim 1, wherein said constructed spatio-temporal analysis image provides a summary of events occurring over said image frames at said line of analysis for one of a duration of said video and a duration of said concatenation of said series of said temporally-successive linear pixel arrays.

5. The computer implemented method of claim 1, wherein a width of each of said linear pixel arrays is substantially identical to a width of said line of analysis, wherein said width of said line of analysis is at least a single pixel.

6. The computer implemented method of claim 1, wherein said concatenation of said series of said temporally-successive linear pixel arrays along said temporal dimension comprises concatenating said linear pixel arrays from every Nth successive image frame in said series of image frames.

7. The computer implemented method of claim 1, further comprising defining one or more lines of analysis by a user for parallelly constructing multiple spatio-temporal analysis images.

8. The computer implemented method of claim 1, wherein said segmentation of said constructed spatio-temporal analysis image comprises foreground segmentation for detecting objects and said events of interest, said foreground segmentation comprising:

modeling a background of said constructed spatio-temporal analysis image;

subtracting said modeled background from said constructed spatio-temporal analysis image for obtaining a foreground of said constructed spatio-temporal analysis image; and

performing segmentation of said obtained foreground for detecting said objects and said events of interest.

9. The computer implemented method of claim 1, wherein said capture of said events of interest at said line of analysis comprises detecting presence of an object, detecting traversal of said object, determining speed of said traversal of said object, determining an object count based on said traversal of one or more objects, and determining duration of said presence of said object.

10. The computer implemented method of claim 9, wherein said determination of said speed of said traversal of said object comprises:

receiving one or more lines of analysis spaced apart from each other by a separation distance on said image frames from a user, wherein said separation distance is based on an actual distance in an actual scene;

constructing one or more spatio-temporal analysis images based on said one or more lines of analysis;

determining presence and times of said presence of said object on said constructed one or more spatio-temporal analysis images using foreground segmentation; and

determining said speed of said traversal of said object based on said separation distance, frame rate of said video, and difference between times of said presence of said object on said constructed one or more spatio-temporal analysis images.

11. A computer implemented system for capturing events of interest by performing a spatio-temporal analysis of a video, comprising:

a moving image capture device that acquires a continuous video stream containing a series of image frames over time, wherein each of said image frames is represented by horizontal spatial coordinates and vertical spatial coordinates of a two dimensional plane;

a video content analyzer provided on a computing device for performing one or more of:

assigning a temporal dimension across said image frames of said video stream, wherein said temporal dimension represents order of said image frames using predefined temporal coordinates;

constructing a spatio-temporal analysis image based on a user-defined line of analysis on each of one or more of said image frames, wherein said spatio-temporal analysis image is constructed by concatenating a series of temporally-successive linear pixel arrays along said temporal dimension, each of said linear pixel arrays comprising an array of pixels underlying said line of analysis defined on said each of said one or more of said image frames; and

an image segmentation module provided on said computing device for segmenting said constructed spatio-temporal analysis image for capturing said events of interest.

12. The computer implemented system of claim 11, further comprising a user interface on said computing device for defining said line of analysis along one or more of said horizontal spatial coordinates, said vertical spatial coordinates and a combination of said horizontal spatial coordinates and said vertical spatial coordinates in one or more of said image frames.

13. The computer implemented system of claim 12, wherein said user interface enables a user to define one or more lines of analysis for parallelly constructing multiple spatio-temporal analysis images.

14. The computer implemented system of claim 11, wherein said constructed spatio-temporal analysis image is represented by one of a combination of a fixed horizontal spatial coordinate, a range of said vertical spatial coordinates, and variable temporal coordinates and a combination of a fixed vertical spatial coordinate, a range of horizontal spatial coordinates, and variable temporal coordinates.

15. The computer implemented system of claim 11, wherein said constructed spatio-temporal analysis image provides a summary of events occurring over said image frames at said line of analysis for one of a duration of said video and a duration of said concatenation of said series of said temporally-successive linear pixel arrays.

16. The computer implemented system of claim 11, wherein a width of each of said linear pixel arrays is substan-

tially identical to a width of said line of analysis, wherein said width of said line of analysis is at least a single pixel.

**17.** The computer implemented system of claim **11**, wherein said image segmentation module performs foreground segmentation of said constructed spatio-temporal analysis image for detecting objects and said events of interest, said image segmentation module comprising:

- a background modeler for modeling a background of said constructed spatio-temporal analysis image;
- a background subtractor for subtracting said modeled background from said constructed spatio-temporal analysis image for obtaining a foreground of said constructed spatio-temporal analysis image; and
- a foreground segmentation module for performing segmentation of said obtained foreground for detecting said objects and said events of interest.

**18.** The computer implemented system of claim **11**, wherein said captured events of interest at said line of analysis comprises presence of an object, traversal of said object, speed of said traversal of said object, an object count based on said traversal of one or more objects, and duration of said presence of an object.

**19.** A computer program product comprising computer executable instructions embodied in a computer readable storage medium, wherein said computer program product comprises:

- a first computer parsable program code for acquiring a continuous video stream containing a series of image frames over time, wherein each of said image frames is represented by horizontal spatial coordinates and vertical spatial coordinates of a two dimensional plane;

- a second computer parsable program code for assigning a temporal dimension across said image frames of said video stream, wherein said temporal dimension represents order of said image frames using predefined temporal coordinates;

- a third computer parsable program code for constructing a spatio-temporal analysis image based on a user-defined line of analysis on each of one or more of said image frames, wherein said spatio-temporal analysis image is constructed by concatenating a series of temporally-successive linear pixel arrays along said temporal dimension, each of said linear pixel arrays comprising an array of pixels along said line of analysis defined on each of one or more of said image frames; and

- a fourth computer parsable program code for segmenting said spatio-temporal analysis image for capturing said events of interest.

**20.** The computer program product of claim **19**, wherein said fourth computer parsable program code for segmenting said spatio-temporal analysis image comprises:

- a fifth computer parsable program code for modeling a background of said constructed spatio-temporal analysis image;

- a sixth computer parsable program code for subtracting said modeled background from said constructed spatio-temporal analysis image for obtaining a foreground of said constructed spatio-temporal analysis image; and

- a seventh computer parsable program code for performing segmentation of said obtained foreground for detecting said objects and said events of interest.

\* \* \* \* \*