



US 20100040764A1

(19) **United States**

(12) **Patent Application Publication**
Schwartz

(10) **Pub. No.: US 2010/0040764 A1**

(43) **Pub. Date: Feb. 18, 2010**

(54) **LATENT PRINT DEVELOPMENT APPARATUS**

Publication Classification

(51) **Int. Cl.**
A61B 5/117 (2006.01)
(52) **U.S. Cl.** 427/1; 118/31.5
(57) **ABSTRACT**

(76) Inventor: **Arnold Schwartz**, Crompond, NY (US)

Correspondence Address:
Ashok Tankha
36 Greenleigh Drive
Sewell, NJ 08080 (US)

A kit, an apparatus, and method are provided for developing a latent print. The apparatus comprises a pellet comprising a substrate impregnated with a sublimation compound, a receptacle, an adapter, and an end cap. The receptacle is open at a first end and detachably connected to a heat source at a second end. The receptacle is designed to receive and accommodate the pellet through the first end of the receptacle. The adapter defines an annular space for transmission of heat from the heat source to the pellet. The first end of the adapter is connected to the second end of the receptacle and the second end of the adapter is in communication with the heat source. The end-cap comprising a mesh window in an annular space of the end-cap allows passage of the fumes released from the pellet through the open end of the end cap towards the latent print for development.

(21) Appl. No.: **12/542,081**

(22) Filed: **Aug. 17, 2009**

Related U.S. Application Data

(60) Provisional application No. 61/189,038, filed on Aug. 15, 2008.

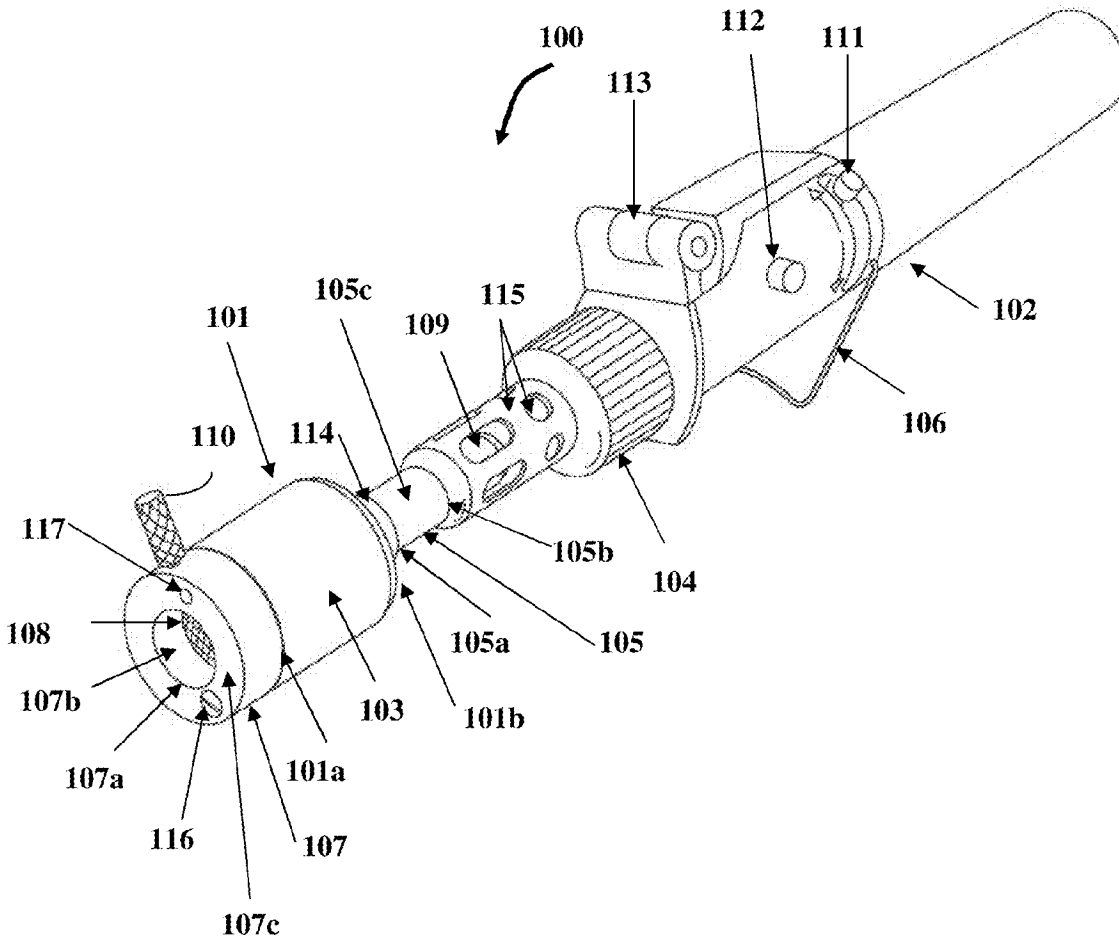

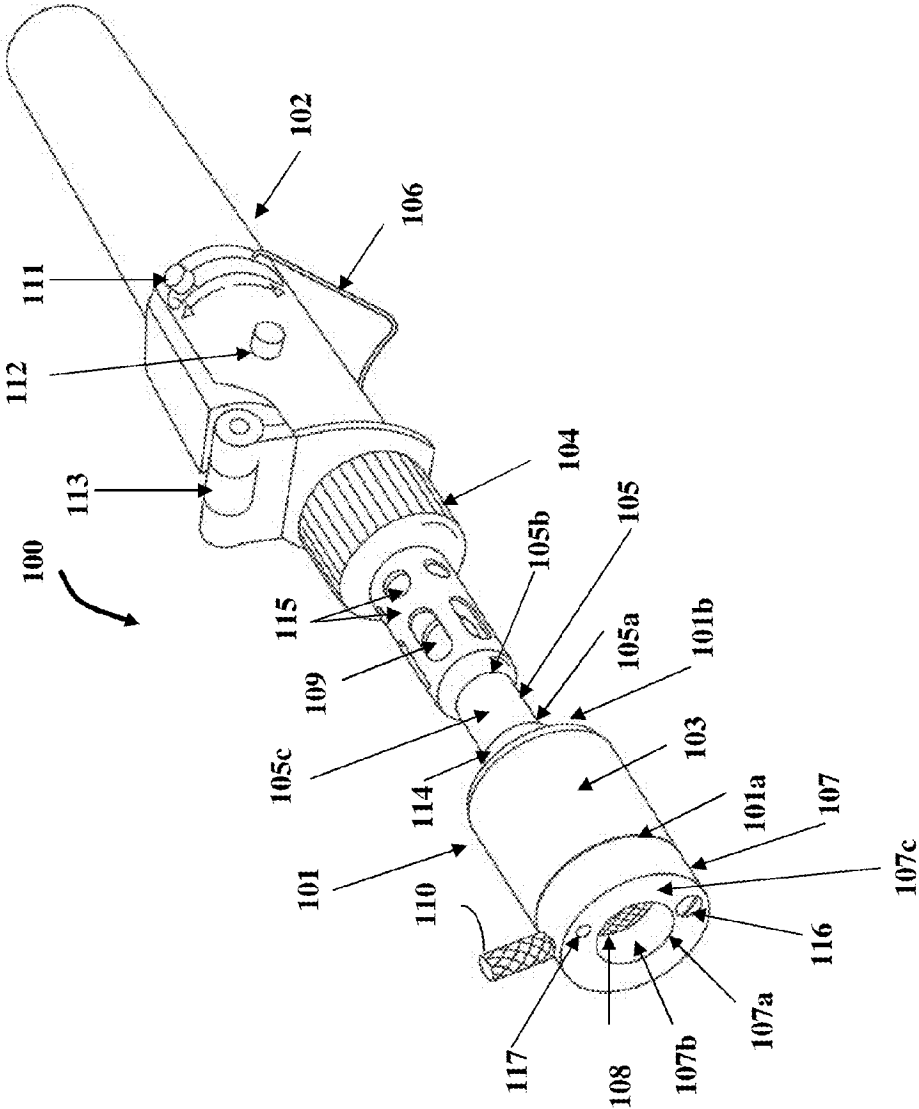

FIG. 1

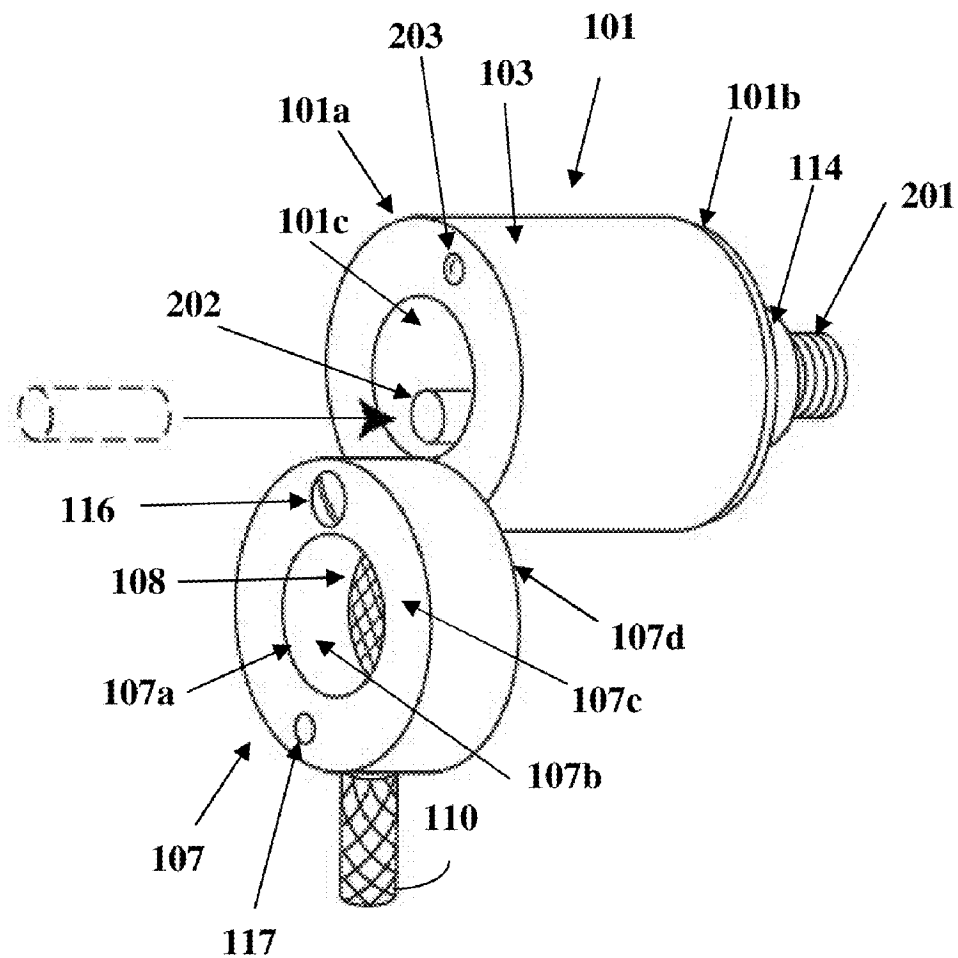

FIG. 2

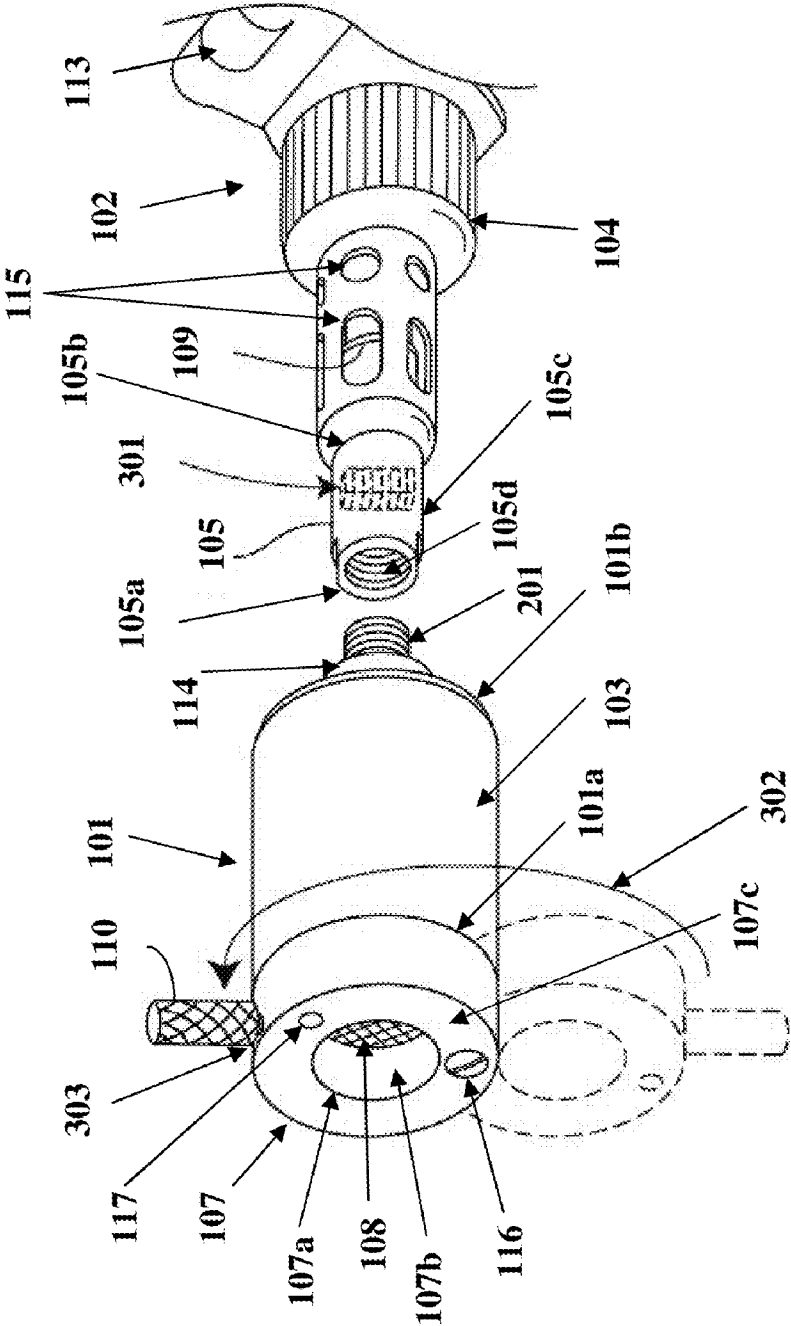

FIG. 3

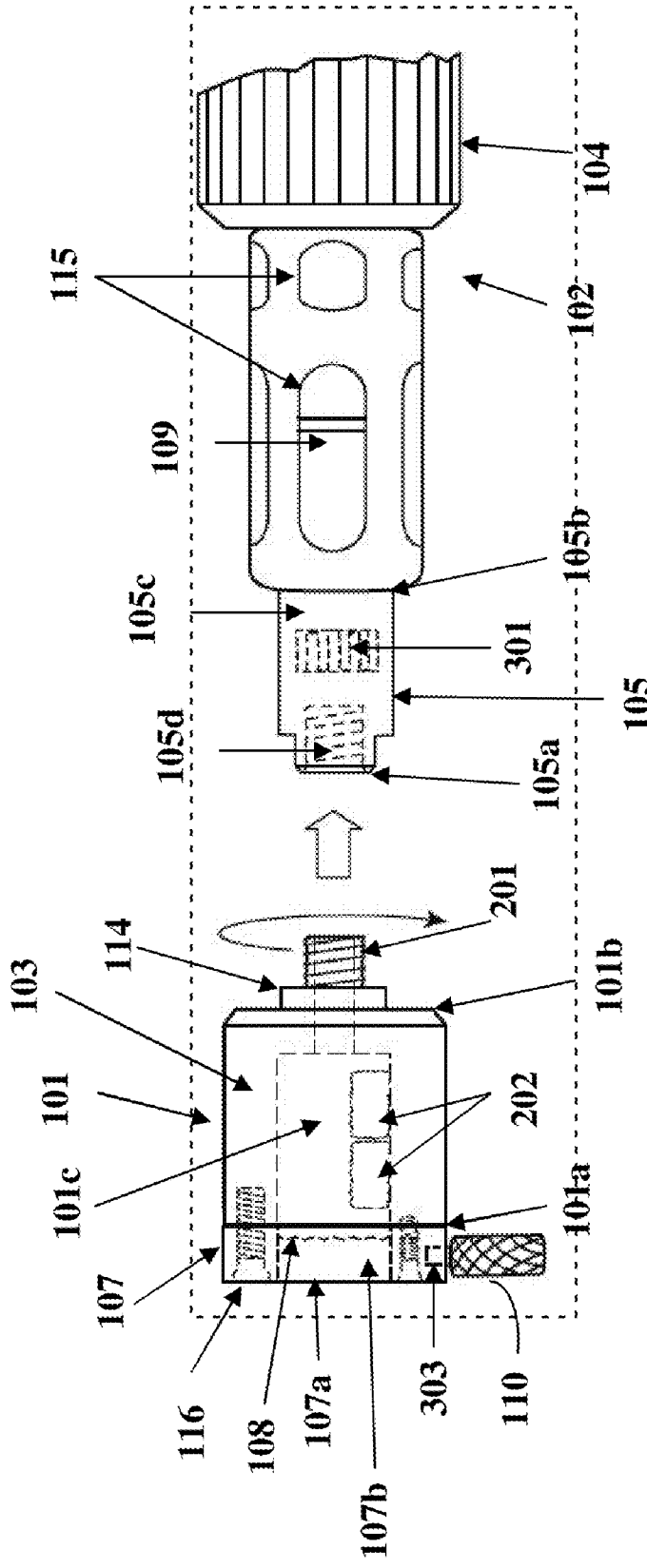

FIG. 4

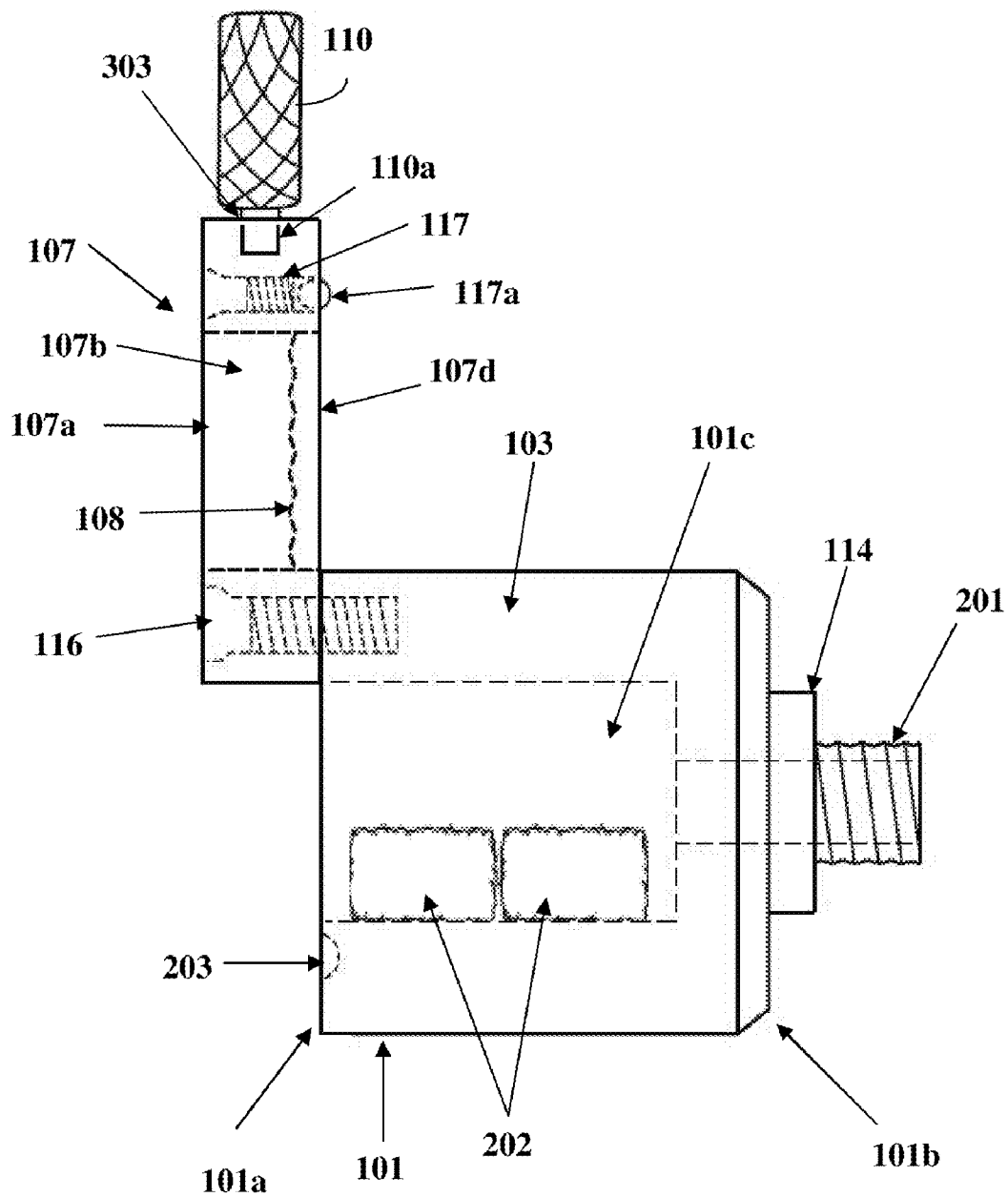

FIG. 5

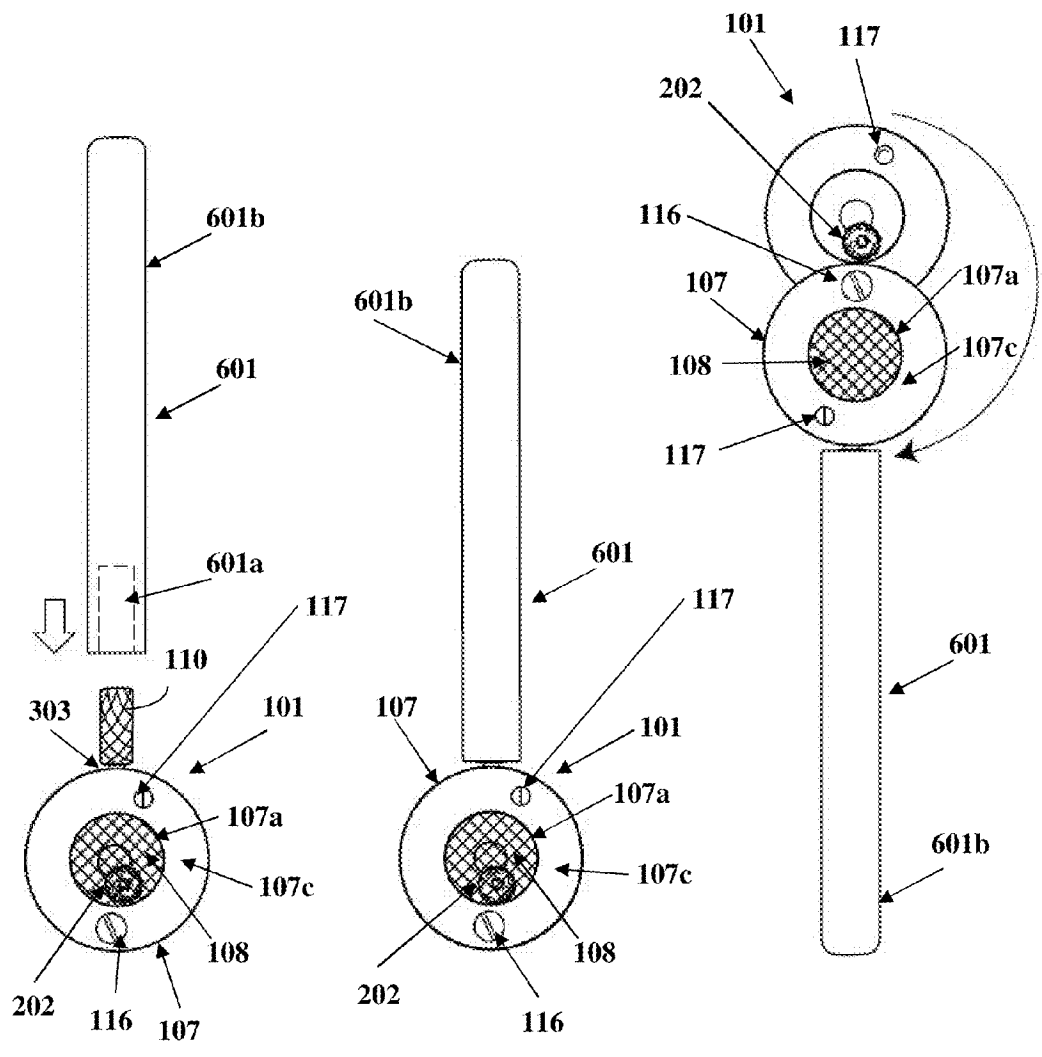

FIG. 6A

FIG. 6B

FIG. 6C

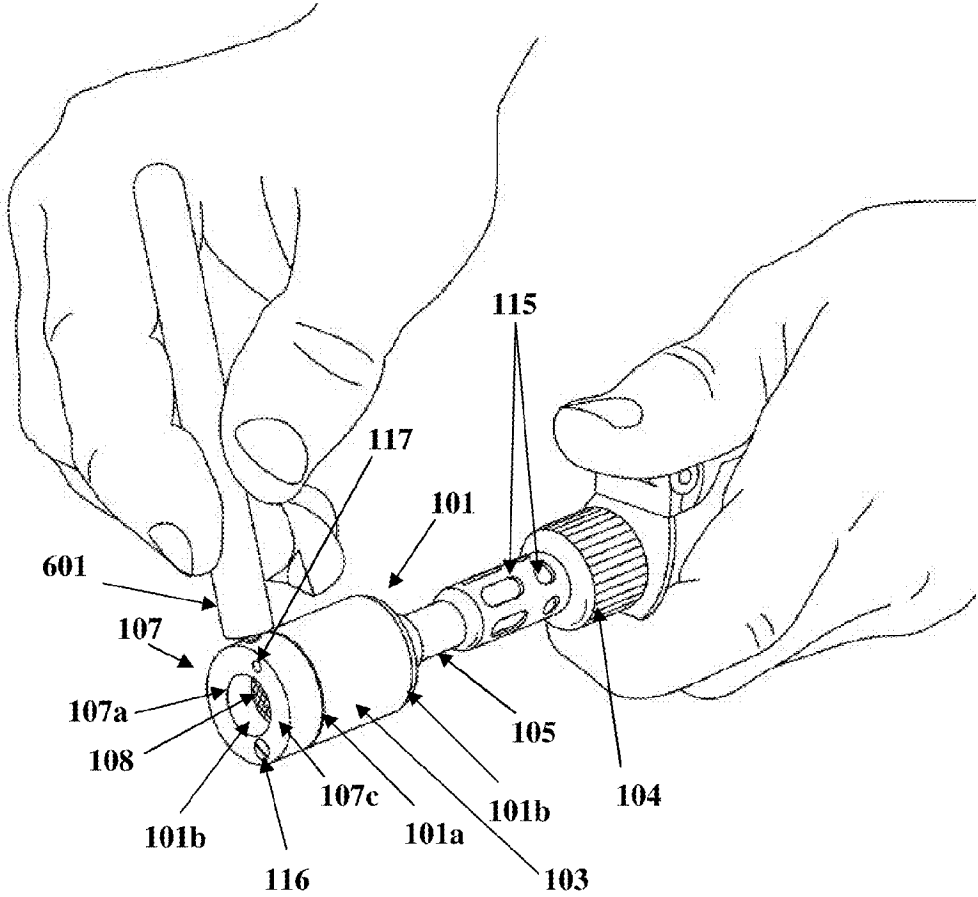

FIG. 7A

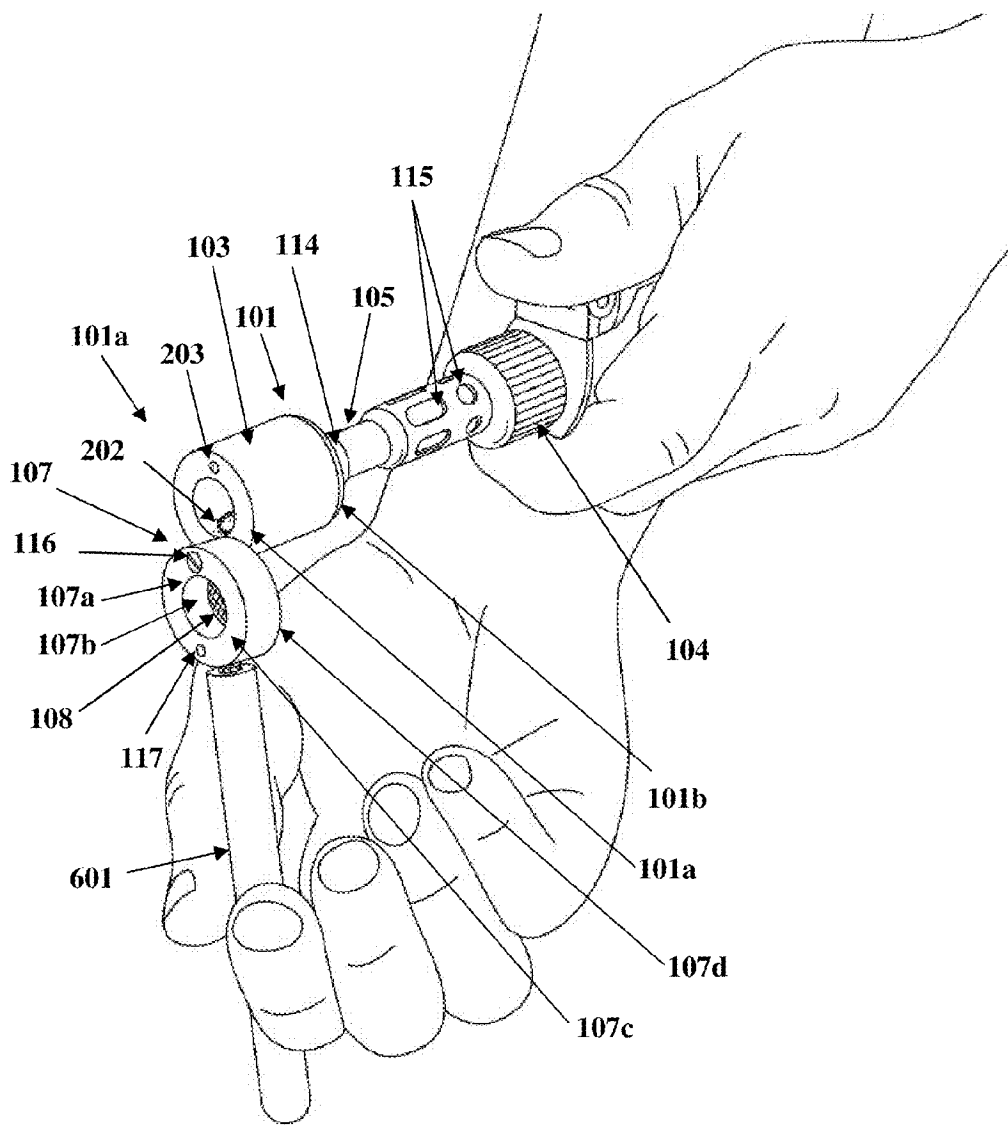

FIG. 7B

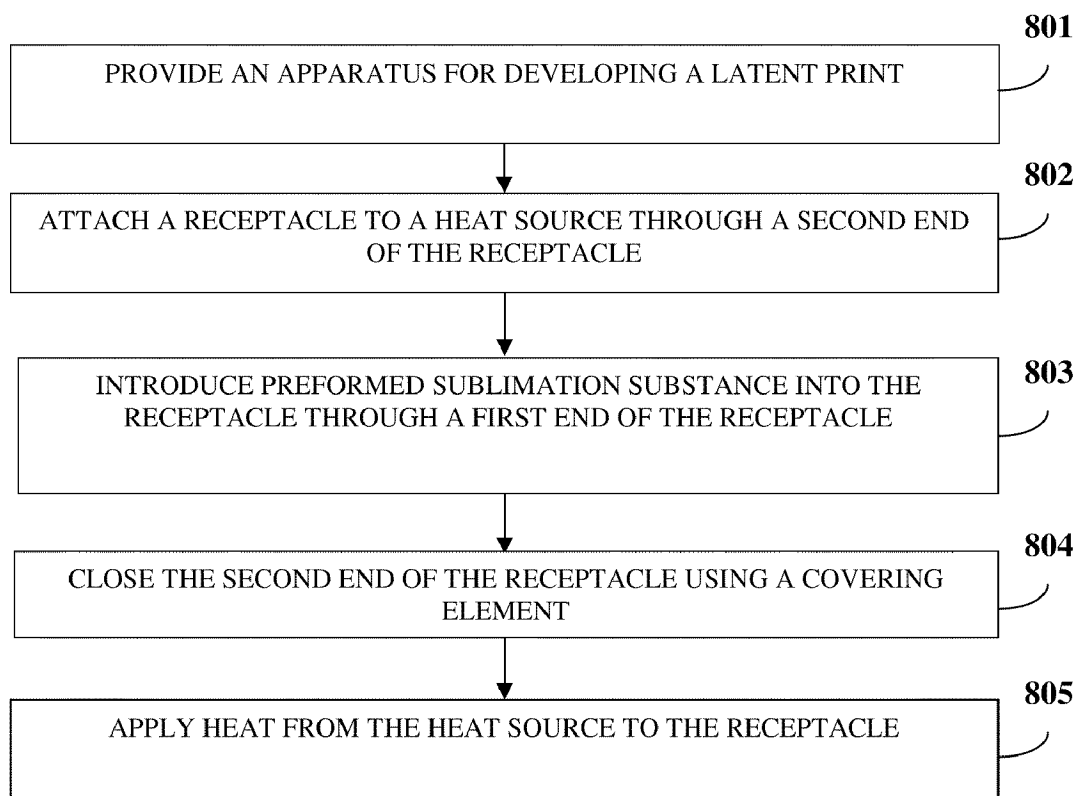

FIG. 8

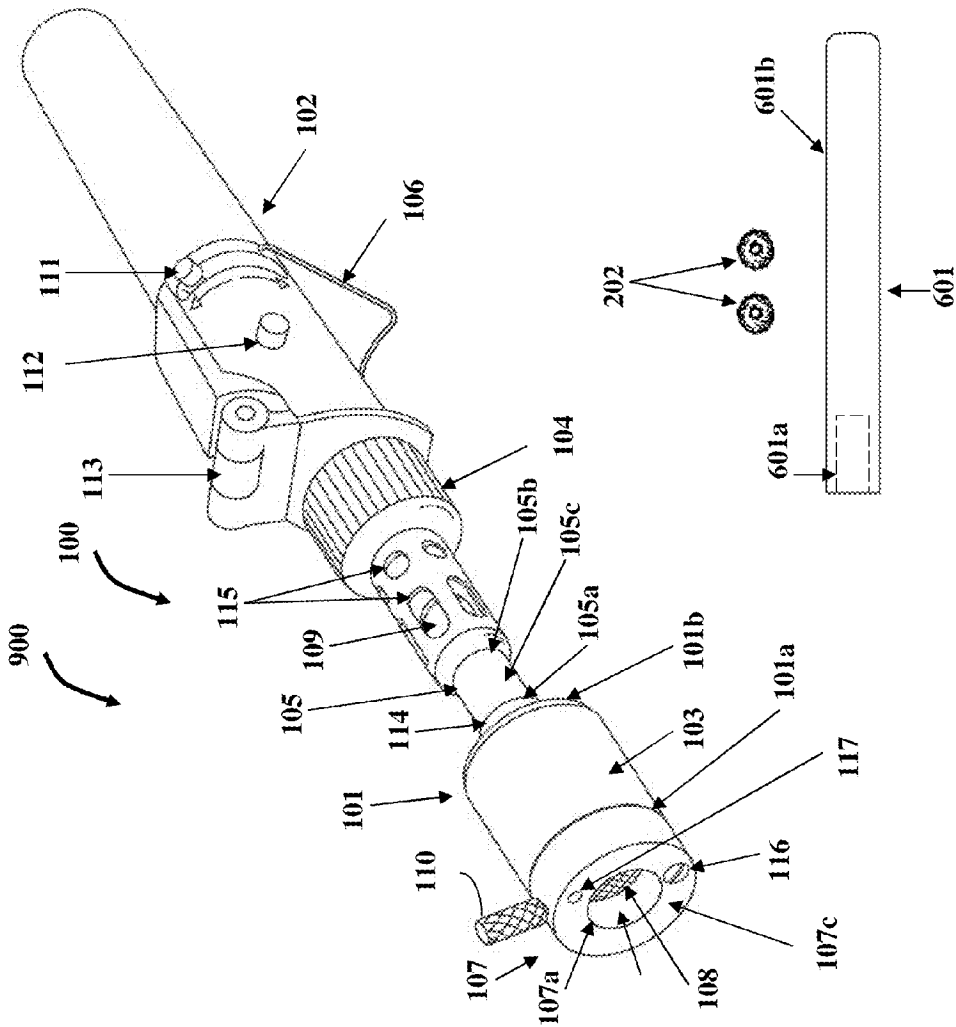

FIG. 9

LATENT PRINT DEVELOPMENT APPARATUS

CROSS REFERENCE TO RELATED APPLICATIONS

[0001] This application claims the benefit of provisional patent application No. 61/189,038 titled “A Proprietary Cartridge Design For A Fuming Wand, For Use In Forensic Latent Print Development”, filed on Aug. 15, 2008 in the United States Patent and Trademark Office.

BACKGROUND

[0002] The apparatus and method disclosed herein, in general, relates to a latent print development apparatus. More particularly, the apparatus and method disclosed herein relates to using a pellet comprising a substrate impregnated with a sublimation compound in a latent print development apparatus. The substrate comprises stainless steel wool, fibrous and porous materials, cotton gauze, flax, etc. The sublimation compound comprises compounds such as cyanoacrylate, etc.

[0003] Cyanoacrylate is used in forensic science for capturing latent prints, for example, fingerprints on non-porous surfaces. When cyanoacrylate is heated beyond its sublimation temperature, cyanoacrylate sublimates into a white vapor that adheres to the residues of a latent print to reveal the print's topography, outline, ridges, etc.

[0004] Former devices and techniques for developing latent finger prints produced fairly good results. However, these devices used techniques that were time consuming, taking several hours, and had to be performed in enclosed spaces. In the late 1990s, a different approach was introduced that allows the devices to be used both indoors and outdoors. This approach also significantly reduced the print development time. However, this approach also has a few drawbacks, such as high operational cost, low ease of use, and the requirement to maintain a constant supply of liquid cyanoacrylate.

[0005] Another device for developing latent fingerprints uses a brass-housing for holding a porous substrate impregnated with cyanoacrylate. The brass-housing is a replaceable cartridge with a one-time use and is relatively expensive. The brass housing is attached to the exhaust port of a handheld butane torch by a friction fit. When the cyanoacrylate gets depleted during the fuming process, the brass housing has to be removed with pliers or tweezers, while the device is still hot, which poses a risk to the user and the surroundings. In addition to the expense incurred for replacing the brass housing when the cyanoacrylate gets depleted, there is a potential for damage when the brass housing is removed, both to the device and the user.

[0006] One recent technique incorporates a butane torch with a metal cartridge that connects directly to a clear plastic fuming housing. This technique uses a metal cartridge encapsulated within which is a marble sized-ball of steel wool positioned between two wire mesh screens. This design allows the user to recharge the steel wool ball, once the cured cyanoacrylate on the substrate is depleted. However, this design has its drawbacks, such as, managing multiple components and additional clean ups, handling of additional cyanoacrylate carried in a small bottle for recharging the steel wool ball, and requiring additional downtime during each recharge, and waiting for the cyanoacrylate to cure.

[0007] Therefore, there is a need for an apparatus and method for developing a latent print that reduces the operational cost, provides ease of use, and does not require any significant downtime between applications.

BRIEF DESCRIPTION OF THE DRAWINGS

[0008] The following detailed description of the invention is better understood when read in conjunction with the appended drawings. For the purpose of illustrating the invention, exemplary constructions of the invention are shown in the drawings. However, the invention is not limited to the specific methods and instrumentalities disclosed herein.

[0009] FIG. 1 illustrates a side perspective view of a latent print development apparatus.

[0010] FIG. 2 exemplarily illustrates a side perspective view of a receptacle and an end cap of the latent print development apparatus.

[0011] FIG. 3 exemplarily illustrates an exploded side perspective view of the latent print development apparatus showing the receptacle, a heat diffuser, a metal adapter, and a section of a heat source.

[0012] FIG. 4 exemplarily illustrates an exploded sectional orthogonal view of the latent print development apparatus showing the receptacle, the metal adapter, and a section of the heat source.

[0013] FIG. 5 exemplarily illustrates a sectional orthogonal view of the receptacle pivotally attached to the end cap.

[0014] FIGS. 6A-6C exemplarily illustrate an embodiment of a removal mechanism of the latent print development apparatus.

[0015] FIG. 7A exemplarily illustrates a user engaging a handle of the end cap in a closed position using an engaging tool.

[0016] FIG. 7B exemplarily illustrates a user engaging a handle of the end cap in an open position using an engaging tool.

[0017] FIG. 8 illustrates a method of developing a latent print.

[0018] FIG. 9 exemplarily illustrates a portable latent print development kit.

DETAILED DESCRIPTION OF THE INVENTION

[0019] An apparatus 100 is provided for developing a latent print. FIG. 1 illustrates a side perspective view of a latent print development apparatus 100. The latent print development apparatus 100 herein referred to as the “apparatus” comprises a pellet 202, a generally cylindrical receptacle 101 that defines an annular inner space 101c with a first end 101a and a second end 101b for housing the removable pellet 202, a generally cylindrical adapter 105 that defines an annular space 105c, and a generally cylindrical end-cap 107 designed to mate with and close the first end 101a of the receptacle 101. The pellet 202 as exemplarily illustrated in FIG. 2 comprises a substrate impregnated with a sublimation compound. The receptacle 101 is open to the environment at the first end 101a through an annular opening 107a in the end-cap 107, and is detachably connected to a heat source 102 through the second end 101b. The receptacle 101 is designed to receive and accommodate the pellet 202 through the first end 101a of the receptacle 101. The adapter 105 shown in FIG. 3 defines an annular space 105c for transmission of heat from the heat source 102 to the pellet 202. The adapter 105 has a first end 105a and a second end 105b. The first end 105a of the adapter

105 is connected to the second end **101b** of the receptacle **101** and the second end **105b** of the adapter **105** is in communication with the heat source **102**, for example a butane torch. The first end **107c** of the end cap **107** has an annular opening **107a**. The end-cap **107** is removably attached to the first end **101a** of the receptacle **101**, for example by a pivotal connection. The annular space **107b** within the end-cap is in fluid communication with the annular space **101c** of the receptacle **101**. The end-cap **107** comprising a mesh window **108** in the annular space **107b** of the end-cap **107** allows fumes released from the pellet **202** to be directed through the annular opening **107a** of the end-cap **107** towards the latent print to enable the development of the latent print.

[0020] The receptacle **101** of the apparatus **100** is an open ended generally cylindrical enclosure **103**. The receptacle **101** is designed to receive and accommodate a removable pellet **202**, as exemplarily illustrated in FIG. 2. The pellet **202** comprises a sintered substrate impregnated with a sublimation compound, for example, a cyanoacrylateco polymer. The pellet **202** is shaped and impregnated with the sublimation compound independent of and external to the receptacle **101**. In an embodiment, the pellet **202** is in the shape of a disc impregnated with the sublimation compound. The pellet **202** is introduced into the annular inner space **101c** of the receptacle **101** through the first end **101a** of the receptacle **101** and releases fumes on application of heat from the heat source **102**. The pellet **202** is dropped into the opening **101c** through the first end **101a** of the receptacle **101**. The diameter of the cylindrical pellet **202** is slightly larger than the opening at the second end **101b**, so that the pellet **202** remains securely held inside the annular inner space **101c** of the receptacle **101** throughout the fuming process. "Fuming process" as used herein refers to the passage of heated air over the cured pellet **202** to produce vapors of the sublimation compound that are directed towards the latent prints. Also, "cured pellet" as used herein refers to the pellet **202** saturated with the sublimation compound.

[0021] The end-cap **107** detachably connects to the first end **101a** of the receptacle **101**, for example, by a pivoting movement **302** of the end-cap **107** about a pivoting point **116** on the first end **101a** of the receptacle **101**, as exemplarily illustrated in FIG. 3. The end-cap **107** is a generally cylindrical housing defining an annular space **107b** with an annular opening **107a** as illustrated in FIGS. 1-9 for allowing the fumes generated to be exhausted through the annular opening **107a** and directed towards the latent print. A mesh window **108**, made, for example, of woven brass wire or aluminum wire, in the end cap **107** is disposed within the annular space **107b** in the end cap **107**. The mesh window **108** traps non-sublimated particles and allows fumes released from the pellet **202** to be directed towards the latent prints.

[0022] FIG. 2 exemplarily illustrates a side perspective view of the receptacle **101** and end cap **107** of the apparatus **100**. The receptacle **101** comprises a coaxial threaded extension **201** at the second end **101b** of the receptacle **101** for attaching the receptacle **101** to the heat source **102**. In an embodiment, the coaxial threaded extension **201** has a metal washer **114** for providing mechanical strength to the neck of the coaxial threaded extension **201**.

[0023] FIG. 3 exemplarily illustrates an exploded side perspective view of the apparatus **100** showing the receptacle **101**, a heat diffuser **301**, the metal adapter **105**, and a section of the heat source **102**. The heat source **102** that is coupled to the receptacle **101** is, for example, a butane torch available

from Porta-Lab™, and is specifically adapted for use in the apparatus **100** disclosed herein. The exhaust port **104** of the heat source **102** is attached to the metal adapter **105**. The metal adapter **105** comprises a female internally threaded extension **105d**. The coaxial threaded extension **201** at the second end **101b** of the receptacle **101** engages the internally threaded extension **105d** of the adapter **105** that is in communication with the heat source **102**.

[0024] FIG. 4 exemplarily illustrates an exploded sectional orthogonal view of the apparatus **100** showing the receptacle **101** with the pellets **202**, impregnated with the sublimation substance, positioned inside the annular inner space **101c**, the end-cap **107** in the closed position, the metal adapter **105**, and a section of the heat source **102** showing the metal adaptor **105** connected to the heat source **102**. The coaxial threaded extension **201** of the receptacle **101** is fastened to the internally threaded extension **105d** of the metal adapter **105**, for connecting the receptacle **101** to the heat source **102**, as exemplarily illustrated in FIG. 4. The apparatus **100** also comprises a support stand **106**, for example, a wire frame stand, assembled to the butane torch **102** such that the resulting distribution of mass inclines the apparatus **100** towards a posterior end of the apparatus **100**, as exemplarily illustrated in FIG. 1 and FIG. 9. The support stand **106** provides hands-free support for the apparatus **100** during the fuming operation. The apparatus **100** is set on the support stand **106** on the floor of a fuming chamber or inserted through a portal cover in a glass frame. The apparatus **100** may include a heat intensity control lever **111**, a safety ignition switch **113**, and a shut-off button **112**, ergonomically located for user control when in operation, as exemplarily illustrated in FIG. 1 and FIG. 9.

[0025] FIG. 5 exemplarily illustrates a sectional orthogonal view of the receptacle **101** showing the pivotally attached end-cap **107** in the open position to allow the insertion or removal of the depleted pellet **202** from the annular space **101c** in the receptacle **101**. As exemplarily illustrated in FIG. 5, the receptacle **101** comprises a ball nose spring locking element **117** that is rigidly attached to the second end **107d** of the end-cap **107**. The ball nose spring locking element **117** comprises a ball nose **117a**. The ball nose **117a** of the ball nose spring locking element **117** engages a depression **203** on the first end **101a** of the receptacle **101** to enable the end cap **107** to be locked to the first end **101a** of the receptacle **101**. The ball nose spring locking element **117** on the end cap **107** is located, for example, near a handle **110** of the end cap **107**. In an embodiment, the ball nose spring locking element **117** also comprises a lock ring (not shown) to hold the ball nose **117a** in place. In another embodiment, the ball nose spring locking element **117** is rigidly attached to the first end **101a** of the receptacle **101**, while the depression **203** is present on the end cap **107**.

[0026] The apparatus **100** further comprises a removal mechanism, for example, **110** or **601** as exemplarily illustrated in FIG. 6A. The removal mechanism **110** or **601** allows the user to remove the pellet **202** from the receptacle **101** when the sublimation compound from the pellet **202** is depleted and to insert a cured pellet **202**, i.e. a pellet impregnated with the sublimation compound. The removal mechanism **110** or **601** enables the user to open the end-cap **107** and to eject the pellet **202** from the receptacle **101**, even when the receptacle **101** is hot so as to allow the use of the fuming process to continue with minimal downtime. FIGS. 6A-6C exemplarily illustrate an embodiment of the removal mecha-

nism 601. A handle 110 is rigidly attached to the end cap 107 at an attachment point 303 that is diametrically opposite to the pivoting point 116 on the first end 101a of the receptacle 101. The handle 110 opens the end-cap 107. The handle 110 is encased in a heat resistant material. The handle 110 doubles as a thumbscrew head that comprises a threaded shank extension 110a that is tightened into an internal threaded cavity in the end cap 107, as exemplarily illustrated in FIG. 5. The removal mechanism is for example an engaging tool. The engaging tool 601 engages with the handle 110 of the end-cap 107. The engaging tool 601 comprises a tool head 601a and an extended handle 601b encased in or made of a heat resistant material, for example, bakelite, polytetrafluoroethylene or Teflon®, etc., to enable the user to safely open the end-cap 107 and remove the pellet 202 depleted of the sublimation compound. The extended handle 601b is made of a heat resistant material.

[0027] FIG. 6A illustrates a front exploded orthogonal view showing the receptacle 101, the end-cap 107, the handle 110, and the engaging tool 601. FIG. 6B illustrates a front orthogonal view showing the engaging tool 601 engaged to the handle 110 of the end-cap 107. FIG. 6C illustrates a front orthogonal view showing the engaging tool 601 engaged to the handle 110 of the end-cap 107, with the end-cap 107 swiveled to an open position. FIG. 7A exemplarily illustrates a user engaging a handle 110 of the end-cap 107 in a closed position using the engaging tool 601. FIG. 7B exemplarily illustrates a user engaging a handle 110 of the end cap 107 in an open position using the engaging tool 601. In an embodiment, the handle 110 is pre-extended in length and encased in or made of a heat resistant material. The extended handle 110 enables the user to safely open the end cap 107 and remove the pellet 202 depleted of the sublimation compound. Although the removal mechanism 110 or 601 has been described herein with reference to the handle 110 and the engaging tool 601, the removal mechanism 110 or 601 is not intended to be limited to the handle 110 and the engaging tool 601; but includes all functionally equivalent structures, for example, handgrips, knobs, pliers, extrinsic tools, etc.

[0028] To feed the pellets 202 into the receptacle 101 the following procedure is followed. The coaxial threaded extension 201 of the receptacle 101 is screwed to the internal thread 105d of the adapter 105. The handle 110 is connected to the end-cap 107, and the end-cover 107 is rotated to the open position 302. One or two sublimation pellets 202 are placed into the enclosure 101c. Holding the butane torch 102 with the receptacle 101 facing upward, the end-cap 107 is rotated to the closed position with the handle 110. The locking elements 117a and 203 will securely hold the end-cap 107 in the closed position. The pellets 202 will remain in the enclosure 103 and may move internally within the enclosure 103c without being expelled from the enclosure 103c as long as the end-cap 107 is in the closed position. The butane torch 102 is now ignited and the receptacle 101 pointed towards the evidence to be investigated. In about two minutes, the heat generated from the butane torch 102 as it passes through the adapter 105, will cause the pellets 202 to begin generating a fume of the sublimation compound. The sublimation fumes are exhausted through the meshing window 108 in the end-cap 107 and directed towards the evidence scene by holding the apparatus in an appropriate position. If a latent print is detected, the sublimation fumes will react with the latent print to develop a permanent image of the latent print within seconds. The sublimation fumes will cease to be generated within about two to

four minutes after the fumes begin to be generated with one sublimation pellet. The butane torch 102 is now turned off.

[0029] To remove the depleted pellets 202, the engaging tool 601 is inserted over the handle 110 attached to the end cap 107. The end cap 107 is then swiveled about the pivoting point 116 to open the receptacle 101. The butane torch 202 is inverted with the receptacle 101 facing downward. The depleted pellets 202 can now be discarded into a non-combustible container. If the depleted pellets 202 tend to stick inside the receptacle 101, a pointed object can be used to dislodge the depleted pellets 202 from the receptacle 101. One or two pellets 202 can now be introduced into the receptacle 101 and the end cap 107 can be closed using the engaging tool 601 and the fuming process can continue.

[0030] FIG. 8 illustrates a method of developing a latent print. An apparatus 100 for developing a latent print, as illustrated and described in the detailed description of FIGS. 1-5, is provided 801. The receptacle 101 is attached 802 to the heat source 102 through the second end 101b of the receptacle 101. The receptacle 101 is attached to the heat source 102 by engaging a coaxial threaded extension 201 of the receptacle 101 to an internally threaded extension 105d of the adapter 105 in communication with the heat source 102. The receptacle 101 receives a pellet 202. The pellet 202 is introduced 803 into the receptacle 101 through the first end 101a of the receptacle 101. The first end 101a of the receptacle 101 is closed 804 with the end-cap 107. The heat source 102 supplies 805 heat to the receptacle 101 and the pellet 202 releases fumes through the open end 107a of the end-cap 107 towards the latent print via the mesh window 108 for development of the latent print. Heat applied from the heat source 102 passes through the heat diffuser 301 to the receptacle 101 via the adapter 105. The pellet 202 releases fumes on application of heat from the heat source 102. The fumes released through the mesh window 108 of the receptacle 101 enable the development of the latent print.

[0031] The end cap 107 is locked to the first end 101a of the receptacle 101 by engaging the ball nose 117a of the ball nose spring locking element 117 on the surface 107a of the end-cap 107 to the depression 203 on the first end 101a of the receptacle 101. The ball nose spring locking element 117 on the end-cap 107 is, for example, located near the handle 110. A removal mechanism, 110 or 601, is provided for removing the pellet 202 from the receptacle 101 when the pellet 202 has been depleted.

[0032] To start the fuming operation, the end cap 107 is swiveled into an open position and one or more pellets 202 impregnated with the sublimation compound are inserted into the receptacle 101. The end cap 107 is then swiveled 302 to a closed position. The fuel supply in the heat source 102, for example, the butane torch 102 is turned on, and a piezo-ignition ignites the butane torch 102. The flame from the butane torch 102 passes through a heat diffuser 301 built into the metal adapter 105 of the butane torch 102 as exemplarily illustrated in FIGS. 3-4. As the flame produced by the ignited butane gases reach the heat diffuser 301, the heat diffuser 301 absorbs the heat from the flames but does not allow the flames to cross the heat diffuser 301 and burn the substrate. The absorbed heat is propagated into the receptacle 101 as heated air. The ceramic material 109, seen through the windows 115 in the metal adapter 105, indicates that the butane gas has been ignited. When the butane torch 102 is burning, the ceramic material 109 glows bright red. The heated heat dif-

fuser **301** drives the superheated air over the pellets **202** which causes the cured cyanoacrylate on the substrate to sublime. The sublimation compound fumes produced are exhausted through the wire mesh window **108**, and directed toward the latent fingerprint evidence to be developed. The white fumes or “bloom” produced reacts with the moisture or other chemical components of the latent print, and causes the latent print to develop within seconds.

[0033] The receptacle **101** is manufactured by a die casting process using, for example, aluminum due to its compatible properties for the intended applications for the apparatus **100** disclosed herein. The receptacle **101** comprises a generally cylindrical enclosure **103** with an annular inner space **101c** and incorporates components, such as the pivotally mounted aluminum end cap **107** comprising a wire mesh window **108**, the thumbscrew handle **110**, and the ball nose spring locking element **117**. The aluminum die cast enclosure **103** is, for example, 13 mm in inner diameter and holds up to two pellets **202** of the sublimation compound per application. A male coaxial threaded extension **201** with, for example, a 4.6 mm opening is designed to fasten to a female threaded extension **105d** of the metal adapter **105** attached to the exhaust port **104** of the specially designed butane torch **102**. The pellet **202**, having a larger diameter, for example, 5 mm is thus held secure inside the annular inner space **101c** of the receptacle **101**.

[0034] Each pellet **202** can generate fumes for 2 to 4 minutes. When the pellet **202** is depleted of the cured cyanoacrylate impregnated on the substrate, the butane torch **102** is turned off. A removal mechanism **110** or **601**, for example, the aluminum engaging tool **601** comprising a Teflon®-encased handle **601b**, is provided that allows the user to safely open the heated enclosure **103** by engaging the handle **110** on the end cap **107**, and remove the depleted pellet **202** from the receptacle **101** in minimal time. A new pellet **202** is dropped into the annular space **101c** of the receptacle **101** and the end cap **107** is closed using the aluminum engaging tool **601**. The butane torch **102** is now reignited, and the process for developing the latent print is continued, without any significant downtime.

[0035] The pellets **202** are manufactured using the following process. The process begins by cutting a strip of sintered stainless steel that is, for example, half an inch across, into smaller pieces. The resulting pieces are, for example, 5/8 of an inch in length and half an inch in width each. These pieces are then rolled into circular pellets **202**. The sintered pellets **202** are then placed in a container into which a measured amount of the sublimation compound, for example cyanoacrylate is added to impregnate the pellet **202** and the impregnated pellets **202** are allowed to dry. The impregnated pellets **202** are packaged in plastic tubes containing pre specified units of impregnated pellets **202** for distribution. In an embodiment, stainless steel is sintered into fine fibers to create the stainless steel sheet that is used as the substrate. Regular steel wool when exposed to moisture over a period of time begins to oxidize or rust, resulting in a potential contaminant.

[0036] In an embodiment, the cyanoacrylate solution is treated with ultraviolet during its preparation. In an example, a solution is prepared by combining 15 grams of the solvent dichloromethane with 1 gram of Sievers’ reagent. This provides a 5% Sievers solution (by weight) that is used as the UV enhancing component. A stainless steel wool pellet is placed into a polypropylene vial, and impregnated with 10 drops of cyanoacrylate. The stainless steel wool pellet is then sprayed

with a curing agent or an accelerator to speed up the curing of the cyanoacrylate. A few drops of the Sievers solution is then added to the impregnated pellet **202**, and allowed to evaporate. The resulting pellet **202** impregnated with the sublimation compound **202** is ready to be placed in the aluminum receptacle **101** of the apparatus **100**, and heated above the sublimation point to produce fumes. The latent print that develops from the fumes is now radiated with a UV light source at about 395 nm wavelength. The developed latent print appears enhanced under a UV light source.

[0037] The primary application of the apparatus **100** is to provide a reliable method to detect and develop latent prints from evidence collected at a crime scene. A crime scene investigator uses the sublimation compound fumes produced by the apparatus **100** to attempt to develop latent prints, for example, fingerprints that may be present on non-porous surfaces of the crime scene evidence. The apparatus **100** is primarily designed for use at outdoor crime scenes, but can be used to develop a print from non-porous materials including metals, glass, varnished woods, plastics, and deceased bodies. The apparatus **100** can also be employed in a forensic laboratory to speed up latent print development in a “cyano” fuming chamber. Due to the portable nature of the apparatus **100**, the evidence tested can be an individual item, inside an enclosed area, for example, an automobile, tent, car trunk, etc., in a forensic laboratory inside an enclosed fume hood, or under an exhaust hood.

[0038] In an embodiment, the method of applying heat from the heat source **102** is modified to exhibit a process used by federal investigation departments called “the microburst method for developing latent prints”. The microburst method applies a very high temperature over a short period of time to the cured cyanoacrylate sublimate. This causes a rapid development of fumes and an almost instant curing of latent prints. The apparatus **100** disclosed herein can be adapted for the microburst method to produce “microburst prints” by removing the heat diffuser **301** from the metal adapter **105** at the neck of the butane torch **102**. The open gas flame from the butane torch **102** is passed directly into the receptacle **101**, exposing the cured pellets **202** of the sublimation compound to extremely high temperatures, and causing almost instant fuming and rapid development of the latent print.

[0039] The apparatus **100** disclosed herein may be included in a portable latent print development kit **900** with component parts capable of being assembled in the field. The portable latent print development kit **900** is exemplarily illustrated in FIG. 9. The portable latent print development kit **900** comprises a pellet **202**, a generally cylindrical receptacle **101**, a generally cylindrical adapter **105**, a generally cylindrical end-cap **107**, and a removal mechanism **110** or **601** as explained in the detailed description of FIGS. 1-5 and FIGS. 6A-6C. The portable latent print development kit **900** further comprises pre specified multiple units of the pellet **202** packaged in plastic containers. One or more units of the pellet **202** are introduced into the receptacle **101** through the second end **101b** of the receptacle **101**, and releases fumes on application of heat from the heat source **102**. The portable latent print development kit **900** further comprises a removal mechanism **110** or **601** for removing the one or more units of the pellet **202** from the receptacle **101** when they are depleted.

[0040] The foregoing examples have been provided merely for the purpose of explanation and are in no way to be construed as limiting of the present invention disclosed herein. While the invention has been described with reference to

various embodiments, it is understood that the words, which have been used herein, are words of description and illustration, rather than words of limitation. Further, although the invention has been described herein with reference to particular means, materials and embodiments, the invention is not intended to be limited to the particulars disclosed herein; rather, the invention extends to all functionally equivalent structures, methods and uses, such as are within the scope of the appended claims. Those skilled in the art, having the benefit of the teachings of this specification, may effect numerous modifications thereto and changes may be made without departing from the scope and spirit of the invention in its aspects.

I claim:

1. An apparatus for developing a latent print, comprising:
 - a pellet comprising a substrate impregnated with a sublimation compound;
 - a generally cylindrical receptacle defining an annular space, said receptacle having a first end and a second end, said receptacle pivotably connected to an end cap at said first end and detachably connected to a heat source at said second end, said receptacle designed to receive and accommodate said pellet through said first end of said receptacle;
 - a generally cylindrical adapter, said adapter defining an annular space for transmission of heat from said heat source to said pellet, said adapter having a first end and a second end, said first end of said adapter connected to said second end of said receptacle and said second end of said adapter in communication with said heat source; and
 - a generally cylindrical end-cap defining an annular space, said end-cap having a first end and a second end, said first end having an annular opening, said second end in detachable communication with said first end of said receptacle, said annular space of the end-cap in fluid communication with the annular space of the receptacle, wherein said end cap comprising a mesh window in said annular space of said end-cap allows passage of said fumes released from said pellet through said annular opening in said end cap to be directed towards said latent print;
 whereby said fumes released through said mesh window of said receptacle enable said development of said latent print.
2. The apparatus of claim 1, wherein said pellet is shaped in the form of a disc impregnated with said sublimation compound.
3. The apparatus of claim 1, wherein said end cap is pivotally connected to said second end of said receptacle at a pivoting point on said second end of said receptacle.
4. The apparatus of claim 1, further comprising a removal mechanism for enabling removal of said pellet from said receptacle when said sublimation compound in said pellet is depleted.
5. The apparatus of claim 4, wherein said removal mechanism is a handle attached to said end cap at an attachment point that is diametrically opposite to a pivoting point on said second end of said receptacle to enable opening of said end cap, wherein said handle is made of a heat resistant material.
6. The apparatus of claim 5, further comprising an engaging tool for engaging said handle of said end cap, wherein said engaging tool comprises a tool head and an extended handle to enable opening of said end cap for removing said pellet

depleted of said sublimation compound from said receptacle, wherein said extended handle is made of a heat resistant material.

7. The apparatus of claim 4, wherein said handle is extended in length to enable safe opening of said end cap for removing said pellet depleted of said sublimation compound from said receptacle.

8. The apparatus of claim 1, further comprising a ball nose spring locking element comprising a ball nose rigidly attached to said end cap, wherein said ball nose of said ball nose spring locking element engages a depression on said second end of said receptacle to enable locking of said end cap to said second end of said receptacle, wherein said ball nose spring locking element on said end cap is located near a handle of said end cap.

9. The apparatus of claim 1, wherein said receptacle comprises a coaxial threaded extension located at said second end of said receptacle for attaching said receptacle to said heat source, wherein said coaxial threaded extension engages an internally threaded extension of said adapter in communication with said heat source.

10. A method of developing a latent print, comprising the steps of:

providing an apparatus for developing said latent print, comprising:

- a pellet comprising a substrate impregnated with a sublimation compound;
 - a generally cylindrical receptacle defining an annular space, said receptacle having a first end and a second end, said first end connected to an end cap and said second end detachably connected to a heat source, said receptacle designed to receive and accommodate said pellet through said first end of said receptacle;
 - a generally cylindrical adapter, said adapter defining an annular space for transmission of heat from said heat source to said pellet, said adapter having a first end and a second end, said first end of said adapter connected to said second end of said receptacle and said second end of said adapter is in communication with said heat source; and
 - a generally cylindrical end-cap with an open end in communication with said first end of said receptacle, wherein said end cap comprising a mesh window in an annular space of said end-cap allows passage of said fumes released from said pellet through said open end of said end cap towards said latent print;
- attaching said receptacle to said heat source through said second end of said receptacle, wherein said receptacle receives said pellet;
- introducing said pellet into said receptacle through a first end of said receptacle;
- closing said first end of said receptacle using said end-cap; and
- applying heat from said heat source to said receptacle, wherein said pellet introduced into said receptacle releases fumes through said open end of said end-cap towards said latent print via said mesh window for enabling said development of said latent print.

11. The method of claim 10, wherein the step of attaching said receptacle to said heat source comprises engaging a coaxial threaded extension of said receptacle to an internally threaded extension of said adapter in communication with said heat source.

12. The method of claim 10, further comprising the step of locking said end-cap to said first end of said receptacle by engaging a ball nose of a ball nose spring locking element on said end cap to a depression on said first end of said receptacle, wherein said ball nose spring locking element is located near a handle of said end cap.

13. The method of claim 10, further comprising the step of providing a removal mechanism for removing said pellet from said receptacle when said sublimation compound in said pellet is depleted.

- 14. A portable latent print development kit, comprising:
 - a pellet comprising a substrate impregnated with a sublimation compound;
 - a generally cylindrical receptacle defining an annular space, said receptacle having a first end and a second end, said receptacle detachably connected to an end-cap at said first end and detachably connected to a heat source at said second end, said receptacle designed to receive and accommodate said pellet through said first end of said receptacle;
 - a generally cylindrical adapter, said adapter defining an annular space for transmission of heat from said heat source to said pellet, said adapter having a first end and a second end, said first end of said adapter connected to said second end of said receptacle and said second end of said adapter is in communication with said heat source; and
 - a generally cylindrical end-cap with an open end in communication with said second end of said receptacle, wherein said end-cap comprising a mesh window in an

annular space of said end-cap allows passage of said fumes released from said pellet through said open end of said end-cap towards said latent print; and
a removal mechanism for removing said pellet from said receptacle when said sublimation compound in said pellet is depleted.

15. The portable latent print development kit of claim 14, wherein said pellet is shaped in the form of a disc impregnated with said sublimation compound.

16. The portable latent print development kit of claim 14, wherein said removal mechanism is a handle attached to said end cap at an attachment point that is diametrically opposite to a pivoting point on said first end of said receptacle to enable opening of said end cap, wherein said handle is made of a heat resistant material.

17. The portable latent print development kit of claim 16, further comprising an engaging tool for engaging said handle of said end cap, wherein said engaging tool comprises a tool head and an extended handle to enable opening of said end cap for removing said pellet depleted of said sublimation compound from said receptacle, wherein said extended handle is made of a heat resistant material.

18. The portable latent print development kit of claim 14, wherein said removal mechanism is an extended handle rigidly attached to said end cap at an attachment point that is diametrically opposite to a pivoting point on said first end of said receptacle to enable said end cap to be opened for insertion or removal of said pellet from said receptacle.

* * * * *